



Air Cylinder Series CS1

Ø 125, Ø 140, Ø 160, Ø 180, Ø 200, Ø 250, Ø 300

Variations

Series	Action	Style	Basic style	Standard variations		Bore size (mm)	Page
				Basic style	Rod boot		
Standard Series CS1  Series CS1  Series CS1W	Double acting	Single rod Series CS1	Lube	●	●	125 140 160 180 200 250 300	1.14-4
			Non-lube	●	●	125 140 160	
			Air-hydro	●	●		
		Double rod Series CS1W	Lube	●	●	125 140 160 180 200 250 300	1.14-23
			Non-lube	●	●	125 140 160	
			Air-hydro	●	●		
Low friction Series CS1□Q 	Double acting	Single rod Series CS1□Q	Non-lube	●	●	125 140 160	1.14-32

CJ1

CJP

CJ2

CM2

C85

C76

CG1

MB

MB1

CP95

C95

C92

CA1

CS1

Applicable Auto Switch (Applicable bore size: Ø 125 to Ø 200 only)

Reed switch	Band mounting	D-A3/A4
	Tie rod mounting	D-A5/A6, D-A59W
Solid state switch	Band mounting	D-G3/K3
	Tie rod mounting	D-F5□/J5□, D-F5NT, D-F5□W/J59W, D-F5BA, D-F5□F

Made to Order

Refer to p.5.4-1 for made to order specifications for series CS1.

Combinations of Standard Products and Made

CS1 Series

- : Standard
- ◎ : Made to Order specifications
- : Special product (Contact SMC for details.)
- : Not available

Symbol	Specification	Applicable bore size	Series		CS1 (Standard)		CS1Q (Low friction)	
			Action/Type	Double acting		Single rod		Double rod
				Lube	Non-lube	Air-hydro	Ø 125 to Ø 160	
				Ø 125 to Ø 300		Ø 125 to Ø 160		
Standard	Standard	Ø 125 to Ø 300	●	●	●	●		
CDS1	Built-in magnet	Ø 125 to Ø 200	●	●	●	●		
CS1□-□ _k	With rod boot	Ø 125 to Ø 300	●	●	●	●		
20-	Copper ^{Note 2)} and Fluorine-free	Ø 125 to Ø 160	—	●	—	—		
XA□	Change of rod end shape	Ø 125 to Ø 300	◎	◎	◎	◎		
XB5	Oversized rod cylinder	Ø 125 to Ø 200	◎	◎	○	○		
XB6	Heat-resistant cylinder (-10 to 150 °C)		—	◎	—	—		
XB7	Cold-resistant cylinder	Ø 125 to Ø 300	○	○	—	—		
XB16	Large-bore air-hydro cylinder	Ø 180 to Ø 200	—	—	◎	◎		
XC3	Special port location	Ø 125 to Ø 300	◎	◎	○	○		
XC4	With heavy duty scraper		◎	◎	○	○		
XC5	Heat-resistant cylinder (-10 to 110 °C)		◎	◎ ^{Note 1)}	—	—		
XC6	Stainless steel		◎	◎	◎	◎		
XC7	Tie-rod, cushion valve, tie-rod nut and similar parts made of stainless steel		○	○	○	○		
XC8	Adjustable stroke cylinder/Adjustable extension type		◎	◎	◎	◎		
XC9	Adjustable stroke cylinder/Adjustable retraction type		Ø 125 to Ø 160	◎	◎	○	○	
XC10	Dual stroke cylinder/Double rod type		Ø 125 to Ø 300	◎	◎	◎	◎	
XC11	Dual stroke cylinder/Single rod type			◎	◎	○	○	
XC12	Tandem cylinder			○	○	○	○	
XC14	Change of trunnion bracket mounting position	◎		◎	○	○		
XC15	Change of tie-rod length	◎		◎	○	○		
XC22	Fluororubber seal	◎		◎ ^{Note 1)}	○	○		
XC26	Clevis pins with flat washer	◎		◎	○	○		
XC27	Double clevis pins made of stainless steel (Stainless steel 304)	◎		◎	○	○		
XC30	Rod side trunnion mounted on the rod cover front	◎		◎	○	○		
XC35	With coil scraper	◎		◎	○	○		
XC39	Special trunnion axis	○	○	○	○			
XC40	Clevis hole with bushing	○	○	○	○			
XC50	Knuckle fixed with nuts	○	○	○	○			
XC68	Hard chrome plated stainless steel rod	◎	◎	○	○			
XC86	With rod end bracket	◎	◎	◎	◎			

Note 1) Applicable I.D.: Ø 125 to Ø 200, Ø 250 and Ø 300 are available upon request for special order.

Note 2) Copper-free for the externally exposed part. For details, refer to the **Web Catalog**.

to Order Specifications

CS1 Series

	CS1 (Standard)			CS1Q (Low friction)
Double acting				
	Double rod			Single rod
	Lube	Non-lube	Air-hydro	Non-lube
	Ø 125 to Ø 300		Ø 125 to Ø 160	
	●	●	●	●
	●	●	●	●
	●	●	●	●
	—	●	—	—
	⊙	⊙	○	⊙
	○	○	○	○
	—	⊙	—	—
	○	○	—	—
	—	—	○	—
	○	○	○	⊙
	⊙	⊙	○	—
	⊙	⊙	—	—
	⊙	⊙	○	○
	○	○	○	○
	—	—	—	○
	—	—	—	○
	—	—	—	○
	—	—	—	○
	—	—	—	—
	⊙	⊙	○	⊙
	⊙	⊙	○	⊙
	○	○	○	—
	—	—	—	⊙
	—	—	—	⊙
	⊙	⊙	○	⊙
	⊙	⊙	○	—
	○	○	○	○
	—	—	—	○
	○	○	○	○
	○	○	○	○
	○	○	○	○
	○	○	○	⊙

CJ1

CJP

CJ2

CM2

C85

C76

CG1

MB

MB1

CP95

C95

C92

CA1

CS1

Air Cylinder/Standard Series CS1

Lube, Non-lube: Ø 125, Ø 140, Ø 160, Ø 180, Ø 200, Ø 250, Ø 300

Air-hydro: Ø 125, Ø 140, Ø 160

How to Order

CS1 **L** **160** **300** **JR**

Mounting

B	Basic
L	Foot
F	Front flange
G	Rear flange
C	Single clevis
D	Double clevis
T	Centre trunnion

Tubing material

Symbol	Bore size (mm)	Tubing material	Stroke range (mm)
—	125, 140	Aluminum tube	1000 or less
	160		1200 or less
	125, 140	Steel tube	1001 or more
	160		1201 or more
F	180 to 300	Steel tube	All stroke
	125, 140		1000 or less
	160		1200 or less

* Refer to page 1.14-5 for the maximum strokes.

Style

—	Lube
N	Non-lube
H	Air-hydro

Bore size

Lube, Non-lube		Air-hydro	
125	125 mm	125	125 mm
140	140 mm	140	140 mm
160	160 mm	160	160 mm
180	180 mm		
200	200 mm		
250	250 mm		
300	300 mm		

Made to order

Refer to page 1.14-5 for details

Rod boot/Cushion

Rod boot	J	Nylon tarpaulin
	K	Heat resistant tarpaulin
Cushion	N	No cushion
	R	With cushion on rod side
	H	With cushion on rod side
	—	With both sides cushion (Air-hydro style: No cushion)

* If specifying more than one symbol, please indicate them in alphabetical order.

** The air-hydro style has no cushion. In case of this style, no symbol indicates no cushion.

Cylinder stroke (mm)

(Refer to p.1.14-5 for max. stroke table.)

Port thread type

—	Rc
TN	NPT
TF	G

Mounting Bracket Part No.

Bore size (mm)	125	140	160	180	200	250	300
Foot*	CS1-L12	CS1-L14	CS1-L16	CS1-L18	CS1-L20	CS1-L25	CS1-L30
Flange	CS1-F12	CS1-F14	CS1-F16	CS1-F18	CS1-F20	CS1-F25	CS1-F30
Single clevis	CS1-C12	CS1-C14	CS1-C16	CS1-C18	CS1-C20	CS1-C25	CS1-C30
Double clevis**	CS1-D12	CS1-D14	CS1-D16	CS1-D18	CS1-D20	CS1-D25	CS1-D30

Refer to p.1.14-9 for How to Order Auto Switches Style.



* Order 2 foot brackets for one cylinder.

** When ordering the double clevis, the clevis pin and the cotter pin (2 pcs.) are attached.

Air Cylinder/Standard *Series CS1*

Specifications

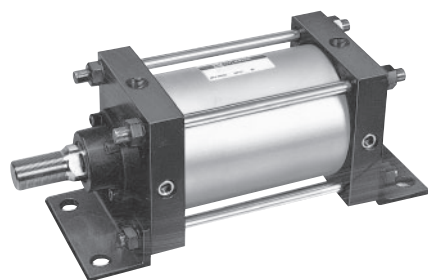

Symbol

Double acting, Air cushion

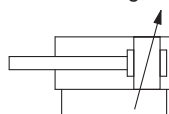

Made to Order Specifications

Symbol	Specifications
-XA□	Change of rod end shape
-XB5	Oversized rod cylinder
-XB6	Heat-resistant cylinder (-10 to 150 °C)
-XC3	Special port location
-XC4	With heavy duty scraper
-XC5	Heat resistant cylinder (110 °C)
-XC6	Made of stainless steel
-XC8	Adjustable stroke cylinder/Adjustable extension type
-XC9	Adjustable stroke cylinder/Adjustable retraction type
-XC10	Dual stroke cylinder/Double rod type
-XC11	Dual stroke cylinder/Single rod type
-XC14	Change of trunnion bracket mounting position
-XC15	Change of tie-rod length
-XC22	Fluororubber seal
-XC26	Clevis pins with flat washer
-XC27	Double clevis pin and double knuckle pin made of stainless steel
-XC30	Rod side trunnion
-XC35	With coil scraper
-XC68	Hard chrome plated stainless steel rod
-XC86	With rod end bracket

Rod Boot Materials

Symbol	Material	Max. ambient temp.
J	Nylon tarpaulin	70 °C
K	Heat resistant tarpaulin	110 °C*

* Max. ambient temperature for the rod boot itself.

Type	Lube, Non-lube	Air-hydro
Bore size (mm)	Ø 125 to Ø 300	Ø 125, Ø 140, Ø 160
Fluid	Air	Turbine oil
Proof pressure	1.57 MPa	
Maximum operating pressure	0.97 MPa	
Minimum operating pressure	0.05 MPa	0.06 MPa
Piston speed	50 to 500 mm/s	0.5 to 200 mm/s
Cushion	Interchangeable	None
Ambient and fluid temperature	0 to 70 °C (No freezing), Air-hydro type: 5 to 60 °C	
Stroke length tolerance (mm)	250 or less ^{st.} : +1.0 ₀ , 251 to 1,000 ^{st.} : +1.4 ₀ , 1,001 to 1,500 ^{st.} : +1.8 ₀ 1501 to 2000 ^{st.} : +2.2 ₀ , 2001 to 2400 ^{st.} : +2.6 ₀	
Mounting	Basic type, Foot type, Rod side flange type, Head side flange type, Single clevis type, Double clevis type, Center trunnion type	

Accessories

Mounting		Basic	Foot	Front flange	Rear flange	Single clevis	Double clevis	Centre trunnion
Standard	Clevis pin, Cotter pin	-	-	-	-	-	●	-
	Rod end nut	●	●	●	●	●	●	●
Accessory	Single knuckle joint	●	●	●	●	●	●	●
	Double knuckle joint (Knuckle pin, Cotter pin)	●	●	●	●	●	●	●
	Rod boot	●	●	●	●	●	●	●

* Refer to p.1.14-21 in case of using rod end nut together with double knuckle joint.

Maximum Stroke

Bore size (mm)	Mounting bracket	Aluminum tube		Steel tube	
		Basic type, Head side flange type Single clevis type, Double clevis type Center trunnion type, Foot type Rod side flange type	Basic type Head side flange type Single clevis type Double clevis type Center trunnion type	Foot type Rod side flange type	
125		1000 or less	1000 or less	1600 or less	
140		1000 or less	1000 or less	1600 or less	
160		1200 or less	1200 or less	1600 or less	
180		—	1200 or less	2000 or less	
200		—	1200 or less	2000 or less	
250		—	1200 or less	2400 or less	
300		—	1200 or less	2400 or less	

Principal Parts Material and Surface Treatment

Description		Material	Note
Cover		Rolled steel plate	Black painted
Tube	Ø 125, Ø 140, Ø 160	Aluminum alloy	Hard anodized
	Ø 180, Ø 200, Ø 250, Ø 300	Carbon steel tube	Inside: Hard chrome plated
Sliding part seal	Lube	NBR	JIS B 2401 O-ring
	Non-lube	NBR	
	Air-hydro	NBR	
Piston rod		Carbon steel	Hard chrome plated
Piston	Lube	Cast iron	
	Non-lube	Aluminum alloy casted (Iron tube: Cast iron)	Chromated (In the case of aluminum alloy casted)
	Air-hydro	Aluminum alloy casted (Iron tube: Cast iron)	Chromated (In the case of aluminum alloy casted)

Series CS1

Weight/Aluminum Tube: Lube (Non-lube, Air-hydro) (kg)

Bore size (mm)		125	140	160	180	200
Basic weight	Basic type	14.85 (13.73)	17.98 (16.57)	24.77 (23.03)	33.44	41.86
	Foot type	16.48 (15.36)	20.50 (19.09)	27.57 (25.83)	37.64	46.74
	Rod side flange type	17.53 (16.41)	22.98 (21.57)	31.16 (29.42)	43.27	53.77
	Head side flange type	17.53 (16.41)	22.98 (21.57)	31.16 (29.42)	43.27	53.77
	Single clevis type	17.92 (16.80)	22.27 (20.86)	30.26 (28.52)	41.83	51.76
	Double clevis type (Clevis pin, Cotter pin)	18.38 (17.26)	23.02 (21.61)	31.11 (29.37)	43.51	53.79
	Trunnion type	18.98 (17.86)	23.71 (22.30)	32.17 (30.43)	44.06	55.85
Additional weight per each 100 mm of stroke		1.77	1.96	2.39	3.24	3.87
Accessory bracket	Single knuckle	0.91	1.16	1.56	3.07	2.90
	Double knuckle (Knuckle pin, Cotter pin)	1.37	1.81	2.48	4.74	4.59
	Rod end nut	0.16	0.16	0.23	0.32	0.85

*1 (): Denotes the non-lube and air-hydro type.

Calculation example: **CS1L160-500**

- Basic weight.....27.57 (Foot type, Ø 160)
- Additional weight.....2.39/100 stroke
- Cylinder stroke.....500 stroke
 $27.57 + 2.39 \times 500/100 = 39.52$ kg

Weight/Steel Tube (kg)

Bore size (mm)		125	140	160	180	200	250	300
Standard weight	Basic type	15.20	18.38	25.24	34.16	42.66	79.78	115.94
	Foot type	16.83	20.90	28.04	38.36	47.54	89.28	133.22
	Rod side flange type	17.88	23.38	31.63	43.99	54.57	101.62	146.14
	Head side flange type	17.88	23.38	31.63	43.99	54.57	101.62	146.14
	Single clevis type	18.27	22.67	30.73	42.55	52.56	98.17	149.22
	Double clevis (Clevis pin, Cotter pin)	18.73	23.42	31.58	44.23	54.59	101.36	154.96
	Trunnion type	19.33	24.11	32.64	44.78	56.65	107.62	156.37
Additional weight per each 100 mm of stroke		2.66	3.01	3.58	4.95	5.75	9.08	12.15
Accessory bracket	Single knuckle	0.91	1.16	1.56	3.07	2.90	5.38	10.82
	Double knuckle (Knuckle pin, Cotter pin)	1.37	1.81	2.48	4.74	4.59	9.22	17.17
	Rod end nut	0.16	0.16	0.23	0.32	0.85	1.26	1.43

Precautions

Be sure to read before handling.
Refer to p.0-39 to 0-43 for Safety Instructions and common precautions.

Warning

Do not use the cylinder as a shock absorber.

- Using the cylinder as a shock absorber may cause damage.

Caution

Do not open the cushion valve excessively.

- If the cushion valve is rotated excessively in the opening direction could be damaged because the portion of the threads that is engaged (counterclockwise), be aware that the valve could slip out, or the threads becomes too short.

Regarding the installation of a knuckle joint:

- Contact SMC if a knuckle joint must be installed on the piston rod by using the rod end nut.

Construction

Lube

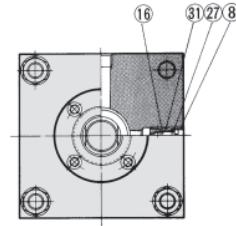
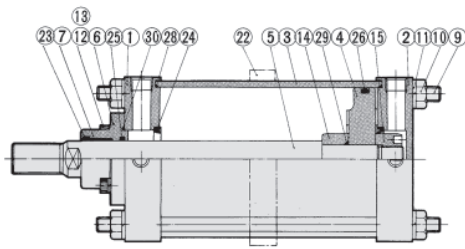
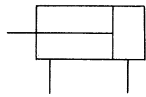

Non-lube

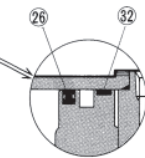
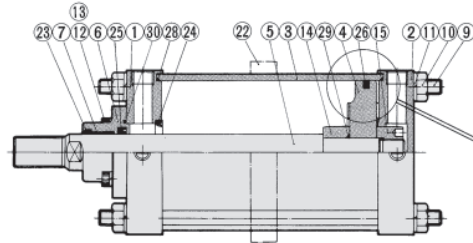
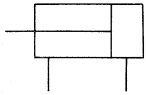

Aluminum tube

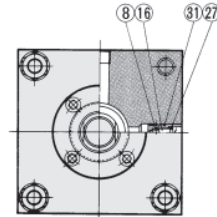

Air-hydro

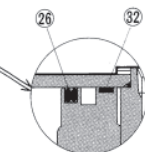
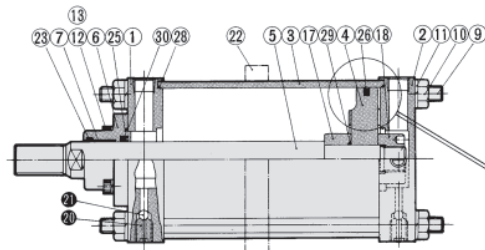
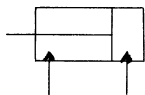

Aluminum tube

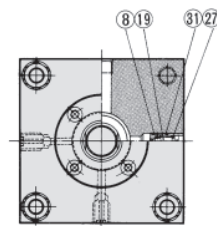

Component Parts

No.	Description	Material	Note
①	Rod cover	Rolled steel plate	Black coated
②	Head cover	Rolled steel plate	Black coated
③	Cylinder tube	Aluminum alloy Carbon steel pipe	Hard anodized Inside: Hard chrome plated
④	Piston	Cast iron **	
⑤	Piston rod	Carbon steel	Hard chrome plated
⑥	Holder plate	Cast iron	Black coating
⑦	Bushing	Lead bronze casting	
⑧	Valve guide	Brass	
⑨	Tie rod	Carbon steel	Chromated
⑩	Tie rod nut	Rolled steel	Black zinc chromated
⑪	Spring washer	Steel wire	Black zinc chromated
⑫	Holder plate bolt	Chrome-molybdenum steel	Black zinc chromated
⑬	Spring washer	Steel wire	Black zinc chromated
⑭	Cushion ring A	Rolled steel	Zinc chromated
⑮	Cushion ring B	Rolled steel	Zinc chromated
⑯	Cushion valve	Rolled steel	Electroless nickel plated
⑰	Spacer A	Rolled steel	Zinc chromated
⑱	Spacer B	Rolled steel	Zinc chromated
⑲	Air releasing valve B	Rolled steel	Zinc chromated
⑳	Air releasing valve A	Chrome-molybdenum steel	
㉑	Check ball	Chrome bearing steel	
㉒	Tie rod reinforcement ring*	Rolled steel	Black coated
㉓	Wear ring	Resin	

* In case of long strokes

** Aluminum tube material of non-lube and air-hydro style is an aluminum alloy die cast.

Seal List

No.	Description	Mat'l	Part No.						
			125	140	160	180	200	250	300

Lube style

㉓	Wiper ring	NBR	SDR-36	SDR-36	SDR-40	SDR-45	SDR-50	SDR-60	SDR-70
㉔**	Cushion seal		DSM-50S	DSM-50S	DSM-50S	DSM-60S	DSM-60S	DSM-75S	PCS-85(R) DSM-75S(H)
㉕	Rod seal		P36	P36	P40	P45	P50A	P60	P70
㉖	Piston seal		P115	P130	P150	P165	P185	P235	P285
㉗	Valve seal		P7	P7	P7	P7	P7	P7	P7
㉘	Tube gasket		C120	C135	C155	C175	C195	CS160-1618-G4	CS160-1618-G5
㉙**	Piston seal		G25	G25	G25	G35	G35	G45	G45
㉚	Holder gasket		G55	G55	G55	G65	G65	G80	G90
㉛**	Guide gasket		N-12.5-1.5	N-12.5-1.5	N-12.5-1.5	N-12.5-1.5	N-12.5-1.5	N-12.5-1.5	N-12.5-1.5

Non-lube style Seals except ㉕ and ㉖ are the same as for the lube-style.

㉕	Rod seal	NBR	PNY-36	PNY-36	PNY-40	PNY-45	PNY-50	PNY-60	PNY-70
㉖	Piston seal		NLP-125A	NLP-140A	NLP-160A	NLP-180A	NLP-200A	NLP-250A	NLP-300A

Air-hydro style Seals except ㉕ and ㉖ are the same as for the lube-style. (Except cushion seal)

㉕	Rod seal	NBR	SKY-36	SKY-36	SKY-40
㉖	Piston seal		RPS-125	RPS-140	RPS-160

Replacement Parts (Seal kits)

- Refer to p.1.14-8 for replacement part no. for air cylinder standard style series CS1.
- ** Seal kits does not include cushion seal, piston seal and guide gasket because they are not replacement parts.

CJ1

CJP

CJ2

CM2

C85

C76

CG1

MB

MB1

CP95

C95

C92

CA1

CS1

Series CS1

Standard Style/Replacement Parts (Seal kits)

When ordering the replacement parts (seal kits) for standard style Series CS1 air cylinders, indicate the order number listed in the table on the right. Each set of replacement parts contains the following: wiper ring, rod seal, piston seal, valve seal, tube gasket, and push plate gasket (for 1 cylinder).

Standard style (Lube)

Bore (mm)	Kit No.	23	25	26	27	28	30
		Wiper ring	Rod seal	Piston seal	Valve seal	Tube gasket	Holder gasket
125	CS1-125A-PS	SDR-36	P36	P115	P7	C120	G55
140	CS1-140A-PS	SDR-36	P36	P130	P7	C135	G55
160	CS1-160A-PS	SDR-40	P40	P150	P7	C155	G55
180	CS1-180A-PS	SDR-45	P45	P165	P7	C175	G65
200	CS1-200A-PS	SDR-50	P50A	P185	P7	C195	G65
250	CS1-250A-PS	SDR-60	P60	P235	P7	CS160-1618-G4	G80
300	CS1-300A-PS	SDR-70	P70	P285	P7	CS160-1618-G5	G90

Standard (Non-lube)

Bore (mm)	Kit No.	23	25	26	27	28	30
		Wiper ring	Rod seal	Piston seal	Valve seal	Tube gasket	Holder gasket
125	CS1N125A-PS	SDR-36	PNY-36	NLP-125A	P7	C120	G55
140	CS1N140A-PS	SDR-36	PNY-36	NLP-140A	P7	C135	G55
160	CS1N160A-PS	SDR-40	PNY-40	NLP-160A	P7	C155	G55
180	CS1N180A-PS	SDR-45	PNY-45	NLP-180A	P7	C175	G65
200	CS1N200A-PS	SDR-50	PNY-50	NLP-200A	P7	C195	G65
250	CS1N250A-PS	SDR-60	PNY-60	NLP-250A	P7	CS160-1618-G4	G80
300	CS1N300A-PS	SDR-70	PNY-70	NLP-300A	P7	CS160-1618-G5	G90

Air-hydro

Bore (mm)	Kit No.	Wiper ring	Rod seal	Piston seal	Valve seal	Tube gasket	Holder gasket
125	CS1H125A-PS	SDR-36	SKY-36	RPS-125	P7	C120	G55
140	CS1H140A-PS	SDR-36	SKY-36	RPS-140	P7	C135	G55
160	CS1H160A-PS	SDR-40	SKY-40	RPS-160	P7	C155	G55

Air Cylinder/With Auto Switch

Series CDS1

Ø 125, Ø 140, Ø 160, Ø 180, Ø 200

How to Order

CDS1 **L** **160** **300** **JR** **A53**

Air cylinder with auto switch

Mounting

B	Basic
L	Foot
F	Front flange
G	Rear flange
C	Single clevis
D	Double clevis
T	Centre trunnion

Style

—	Lube
N	Non-lube
H	Air-hydro

Bore size

Lube, Non-lube		Air-hydro	
125	125 mm	125	125 mm
140	140 mm	140	140 mm
160	160 mm	160	160 mm
180	180 mm		
200	200 mm		

Port thread type

—	Rc
TN	NPT
TF	G

Number of auto switches

—	2
3	3
S	1
n	n

Auto switch

—	Without auto switch
---	---------------------

*Select the applicable auto switch from the table below.

Rod boot/Cushion

Rod boot		
J		Nylon tarpaulin
K		Heat resistant tarpaulin
N		No cushion
R		With cushion on rod side
H		With cushion on head side
—		With both sides cushion (Air-hydro style: No cushion)

Cylinder stroke

(Refer to p.1.14-10 for Max./Min. stroke table.)

Made to Order
(Refer to page 1.14-10 for details.)

Built-in magnet cylinder model

If a built-in magnet cylinder without auto switch is required, there is no need to enter the symbol for auto switch. (Example) CDS1B125-200

Applicable Auto Switches/Refer to auto switch guide for further information on auto switches.

Type	Special function	Electrical entry	Indicator/light	Wiring (Output)	Load voltage		Auto switch model		Lead wire length (m)				Pre-wired connector	Applicable load												
					DC	AC	Tie-rod mounting	Band mounting	0.5 (—)	1 (M)	3 (L)	5 (Z)														
Solid state auto switch	—	Grommet	—	3-wire (NPN)	24 V	5 V, 12 V	—	M9N	●	●	●	○	—	—	—											
				3-wire (PNP)				M9P	●	●	●	○														
		2-wire		Terminal conduit	5 V, 12 V	—	G39	—	—	—	—	—	—	—	—	—										
		2-wire			12 V	—	K39	—	—	—	—	—	—	—	—											
	Diagnostic indication (2-color indicator)	Grommet	Yes	3-wire (NPN)	24 V	5 V, 12 V	—	M9NW	●	●	●	○	—	—	—	—										
				3-wire (PNP)				M9PW	●	●	●	○														
				2-wire				M9BW	●	●	●	○														
				3-wire (NPN)				M9NA*1	—	○	○	●					○	○								
				3-wire (PNP)				M9PA*1	—	○	○	●					○	○								
				2-wire				M9BA*1	—	○	○	●					○	○								
Water resistant (2-color indicator)	Grommet	Yes	4-wire (NPN)	24 V	5 V, 12 V	—	F59F	●	—	●	○	—	—	—	—											
			2-wire (Non-polar)				P3DWA	●	—	●	●					○										
Reed auto switch	—	Grommet	Yes	3-wire (NPN equivalent)	24 V	12 V	100 V	A96	●	—	●	—	—	—	—	—										
				12 V				100 V	A93	●	●	●					—									
				5 V, 12 V				100 V or less	A90	●	—	●					—									
				100 V, 200 V				200 V or less	A54	●	—	●					●									
				2-wire				200 V or less	A64	●	—	●					—									
		Terminal conduit		Yes				No	2-wire	24 V	12 V	100 V, 200 V					—	—	—	—	—	—	—	—	—	
																	—	A33	—	—	—					—
																	—	A34	—	—	—					—
																	—	A44	—	—	—					—
																	—	A59W	●	—	●					—
DIN terminal	Yes	No	2-wire	24 V	100 V, 200 V	100 V, 200 V	—	—	—	—	—	—	—	—	—											
							—	—	—	—	—															
Diagnostic indication (2-color indicator)	Grommet	Yes	2-wire	24 V	100 V, 200 V	100 V, 200 V	—	—	—	—	—	—	—	—	—											
							—	—	—	—	—															

*1 Water resistant type auto switches can be mounted on the above models, but in such case SMC cannot guarantee water resistance.

Consult with SMC regarding water resistant types with the above model numbers.

* Lead wire length symbols: 0.5 m — (Example) M9NW * Solid state auto switches marked with "○" are produced upon receipt of order.
 1 m M (Example) M9NWM
 3 m L (Example) M9NWL
 5 m Z (Example) M9NWZ

* Since there are other applicable auto switches than listed above, refer to page 1.14-36 for details.

* For details about auto switches with pre-wired connector, refer to auto switch guide.

* D-A9□/M9□/M9□W/M9□A/P3DWA□ auto switches are shipped together (not assembled). (Only auto switch mounting brackets are assembled before shipped.)

Series CDS1



Symbol

Double acting, Air cushion

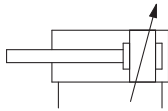

Made to Order Specifications

Symbol	Specifications
-XA□	Change of rod end shape
-XB5	Oversized rod cylinder
-XC3	Special port location
-XC4	With heavy duty scraper
-XC6	Piston rod and rod end nut made of stainless steel
-XC8	Adjustable stroke cylinder/Adjustable extension type
-XC9	Adjustable stroke cylinder/Adjustable retraction type
-XC10	Dual stroke cylinder/Double rod type
-XC11	Dual stroke cylinder/Single rod type
-XC14	Change of trunnion bracket mounting position
-XC15	Change of tie-rod length
-XC22	Fluororubber seal
-XC26	Clevis pins with flat washer
-XC27	Double clevis pin and double knuckle pin made of stainless steel
-XC30	Rod side trunnion
-XC35	With coil scraper
-XC68	Hard chrome plated stainless steel rod
-XC86	With rod end bracket

⚠ Precautions

Be sure to read before handling. Refer to p.0-44 to 0-46 for common precautions of auto switch.

Dimensions of auto switches style

Refer to p.1.14-14 to 1.14-20 for dimensions of auto switch style (according to mounting bracket).

Specifications

Style	Lube, Non-lube		Air-hydro
Fluid	Air		Turbine oil
Bore size (mm)	Ø 125, Ø 140, Ø 160	Ø 180, Ø 200	Ø 125, Ø 140, Ø 160
Proof pressure	1.57MPa	1.2MPa	1.57MPa
Max. operating pressure	0.97MPa	0.7MPa	0.97MPa
Min. operating pressure	0.05MPa		0.06MPa
Piston speed	50 to 500 mm/s		0.5 to 200 mm/s
Cushion	With		Without
Ambient and fluid temperature	0 to 60 °C (No freezing), Air-hydro style: 5 to 60 °C		
Thread tolerance	JIS class 2		
Stroke length tolerance (mm)	250 or less: $^{+1.0}_0$, 251 to 1,000: $^{+1.4}_0$, 1,001 to 1,500: $^{+1.8}_0$		
Mounting	Basic, Foot, Front flange, Rear flange, Single clevis, Double clevis, Centre trunnion		

Max. Stroke

(mm)

Bore size	Max. stroke	
	Basic, Rear flange, Single clevis, Double clevis, Centre trunnion	Foot, Front flange
Ø 125, Ø 140	1000 or less	1400 or less
Ø 160	1200 or less	1400 or less
Ø 180	1200 or less	1500 or less
Ø 200	998 or less	998 or less
Note	Ø 200: Cylinders of the stroke range of 998 to 1200 are special products.	Ø 200: Cylinders of the stroke range of 998 to 1500 are special products.

Mounting Bracket Part No.

Bore size (mm)	125	140	160	180	200
Foot*	CS1-L12	CS1-L14	CS1-L16	CS1-L18	CS1-L20
Flange	CS1-F12	CS1-F14	CS1-F16	CS1-F18	CS1-F20
Single clevis	CS1-C12	CS1-C14	CS1-C16	CS1-C18	CS1-C20
Double clevis**	CS1-D12	CS1-D14	CS1-D16	CS1-D18	CS1-D20



* Order 2 foot brackets for one cylinder.

** When ordering the double clevis, the clevis pin and the cotter pin (2 pcs.) are attached.

Air Cylinder/With Auto Switch *Series CDS1*

Major Materials and Surface Treatments

Description		Material	Note
Cover		Rolled steel	Black coated
Tube	Ø 125, Ø 140, Ø 160 Ø 180, Ø 200	Aluminum alloy	Hard anodized
Sliding seals	Lube	NBR	JIS B2401 O ring*
	Non-lube	NBR	PNY, NLP
	Air-hydro	NBR	SKY, RPS
Piston rod		Carbon steel	Hard chrome plated
Piston		Aluminum alloy cast	Chromated



* Foot, Front flange: In case of bore size of Ø 125 and Ø 140, the stroke range is 1001 to 1400. In case of Ø 160, piston seals of the stroke range 1200 to 1400 are NLP.
* In case of bore size Ø 180 and Ø 200, piston seals are NLP.

Weight

(kg)

Bore size (mm)		Ø 125	Ø 140	Ø 160	Ø 180	Ø 200
Basic weight	Basic	13.79	16.64	23.11	27.55	36.11
	Foot	15.42	19.16	25.91	31.75	40.99
	Front flange	16.47	21.64	29.50	37.38	48.02
	Rear flange	16.47	21.64	29.50	37.38	48.02
	Single clevis	16.86	20.93	28.60	35.94	46.01
	Double clevis (Clevis pin, Cotter pin)	17.32	21.68	29.45	37.62	48.04
	Trunnion	17.92	22.37	30.51	38.71	50.10
Additional weight per 100 stroke		1.77	1.96	2.39	2.85	3.42
Accessory	Single knuckle joint	0.91	1.16	1.56	3.07	2.90
	Double knuckle joint (Knuckle pin, Cotter pin)	1.37	1.81	2.48	4.74	4.59
	Rod end nut	0.16	0.16	0.23	0.32	0.85

CJ1

CJP

CJ2

CM2

C85

C76

CG1

MB

MB1

CP95

C95

C92

CA1

CS1

Series C□S1

With Auto Switch/Replacement Parts (Seal kits)

When ordering the replacement parts (seal kits) for Series CDS1 cylinder with auto switches, indicate the order number listed in the table on the right.

Each set of replacement parts contains the following: wiper ring, rod seal, piston seal, valve seal, tube gasket, and push plate gasket (for 1 cylinder).

Lube style 1

Bore (mm)	Kit No.	Wiper ring	Rod seal	Piston seal	Valve seal	Tube gasket	Holder plate gasket
125	CS1-125A-PS	SDR-36	P36	P115	P7	C120	G55
140	CS1-140A-PS	SDR-36	P36	P130	P7	C135	G55
160	CS1-160A-PS	SDR-40	P40	P150	P7	C155	G55
180	CDS1-180A-PS	SDR-45	P45	NLP-180A	P7	C175	G65
200	CDS1-200A-PS	SDR-50	P50A	NLP-200A	P7	C195	G65

Non-lube Style

Bore (mm)	Kit No.	Wiper ring	Rod seal	Piston seal	Valve seal	Tube gasket	Holder plate gasket
125	CS1N125A-PS	SDR-36	PNY-36	NLP-125A	P7	C120	G55
140	CS1N140A-PS	SDR-36	PNY-36	NLP-140A	P7	C135	G55
160	CS1N160A-PS	SDR-40	PNY-40	NLP-160A	P7	C155	G55
180	CS1N180A-PS	SDR-45	PNY-45	NLP-180A	P7	C175	G65
200	CS1N200A-PS	SDR-50	PNY-50	NLP-200A	P7	C195	G65

Lube Style 2*

Bore (mm)	Kit No.	Wiper ring	Rod seal	Piston seal	Valve seal	Tube gasket	Holder plate gasket
125	CDS1L125A-PS	SDR-36	P36	NLP-125A	P7	C120	G55
140	CDS1L140A-PS	SDR-36	P36	NLP-140A	P7	C135	G55
160	CDS1L160A-PS	SDR-40	P40	NLP-160A	P7	C155	G55

* Foot, Front flange: Ø 125, Ø 140—1001 to 1400 stroke Ø 160—1200 to 1400 stroke

Air-hydro Style

Bore (mm)	Kit No.	Wiper ring	Rod seal	Piston seal	Valve seal	Tube gasket	Holder plate gasket
125	CS1H125A-PS	SDR-36	SKY-36	RPS-125	P7	C120	G55
140	CS1H140A-PS	SDR-36	SKY-36	RPS-140	P7	C135	G55
160	CS1H160A-PS	SDR-40	SKY-40	RPS-160	P7	C155	G55

Air Cylinder/With Auto Switch *Series CDS1*

Construction

Lube

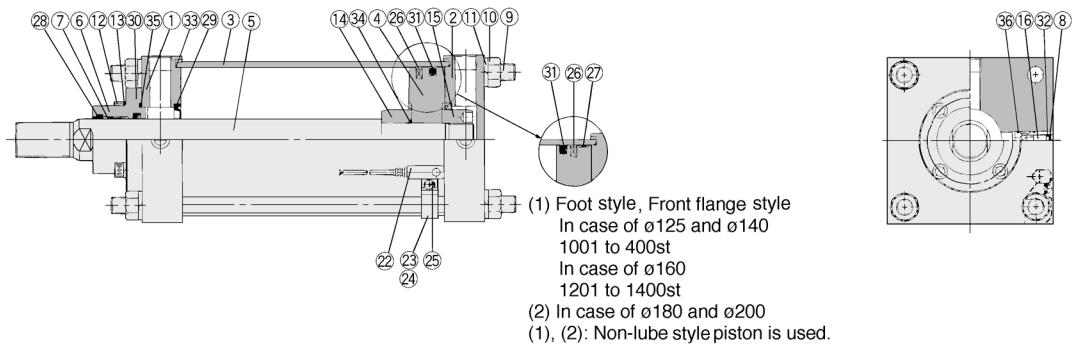
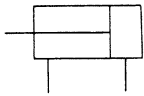

Non-lube

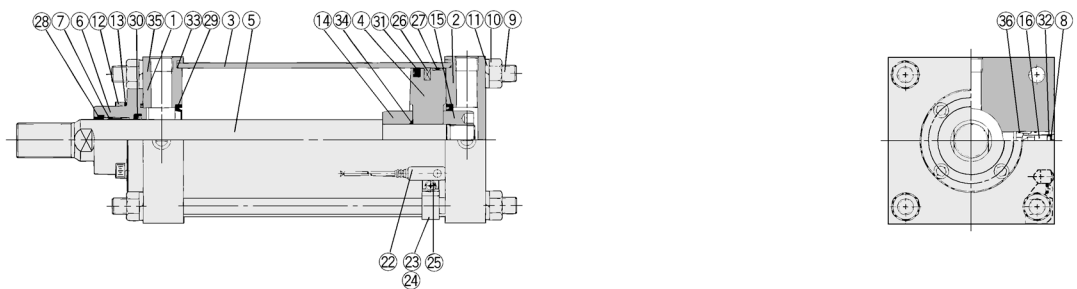
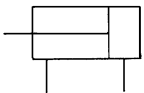

Air-hydro/ $\phi 125$, $\phi 140$, $\phi 160$

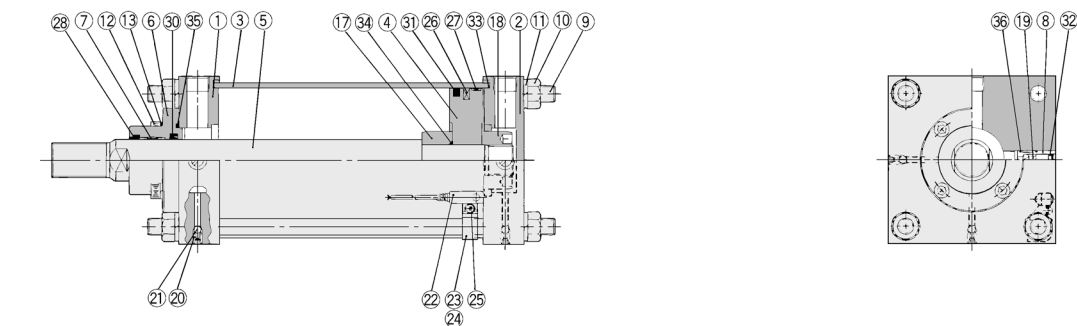
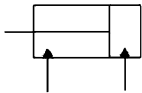

CJ1

CJP

CJ2

CM2

C85

C76

CG1

MB

MB1

CP95

C95

C92

CA1

CS1

Component Parts

No.	Description	Material	Note
①	Rod cover	Rolled steel	Black coated
②	Head cover	Rolled steel	Black coated
③	Cylinder tube	Aluminum alloy	Hard anodized
④	Piston	Aluminum alloy cast iron	Chromate
⑤	Piston rod	Carbon steel	Hard chrome plated
⑥	Holder plate	Cast iron	Black coated
⑦	Bush	Lead bronze casting	
⑧	Valve guide	Brass	
⑨	Tie rod	Carbon steel	Chromated
⑩	Tie rod nut	Rolled steel	Black zinc chromated
⑪	Spring washer	Steel wire	Black zinc chromated
⑫	Holder plate bolt	Chrome-molybdenum steel	Black zinc chromated
⑬	Spring washer	Steel wire	Black zinc chromated
⑭	Cushion ring A	Rolled steel	Zinc chromated
⑮	Cushion ring B	Rolled steel	Zinc chromated
⑯	Cushion valve	Rolled steel	Electroless nickel plated
⑰	Spacer A	Rolled steel	Zinc chromated
⑱	Spacer B	Rolled steel	Zinc chromated
⑲	Air releasing valve B	Rolled steel	Zinc chromated
⑳	Air releasing valve A	Chrome-molybdenum steel	
㉑	Check ball	Chrome bearing steel	
㉒	Auto switch	--	
㉓	Set screw	Chrome-molybdenum steel	Zinc chromated
㉔	Switch mounting bracket	Aluminum alloy	
㉕	Switch mounting screw	Copper wire	Nickel plated
㉖	Magnet	--	
㉗	Wear ring	Resin	

Seal List

No.	Description	Material	Part No.				
			125	140	160	180	200
⑳	Wiper ring		SDR-36	SDR-36	SDR-40	SDR-45	SDR-50
㉑*	Cushion seal		DSM-50S	DSM-50S	DSM-50S	DSM-60S	DSM-60S
⑳	Rod seal		P36	P36	P40	P45	P50A
㉑	Piston seal		P115	P130	P150	NLP-180A	NLP-200A
㉒	Valve seal	NBR	P7	P7	P7	P7	P7
㉓	Tube gasket		C120	C135	C155	C175	C195
㉔*	Piston gasket		G25	G25	G25	G35	G35
㉕	Holder plate gasket		G55	G55	G55	G65	G65
㉖*	Guide gasket		CA50-1607	CA50-1607	CA50-1607	CA50-1607	CA50-1607

Non-lube Style Seals except ㉑ and ㉑ are the same as lube style.

㉑	Rod seal	NBR	PNY-36	PNY-36	PNY-40	PNY-45	PNY-50
㉑	Piston seal		NLP-125A	NLP-140A	NLP-160A	NLP-180A	NLP-200A

Air-hydro Style Seals except ㉑ and ㉑ are the same as lube style.

㉑	Rod seal	NBR	SKY-36	SKY-36	SKY-40
㉑	Piston seal		RPS-125	RPS-140	RPS-160

Replacement Parts (Seal kits)

- Refer to p.1.14-12 for replacement part No. (seal kits) of cylinder with auto switch series CDS1.
- * Seal kits does not include cushion seal, piston seal and guide gasket because they are not replacement parts.

Series C□S1

Basic/CS1B

Lube (CS1B), Non-lube (CS1BN), Air-hydro (CS1BH)

With rod boot

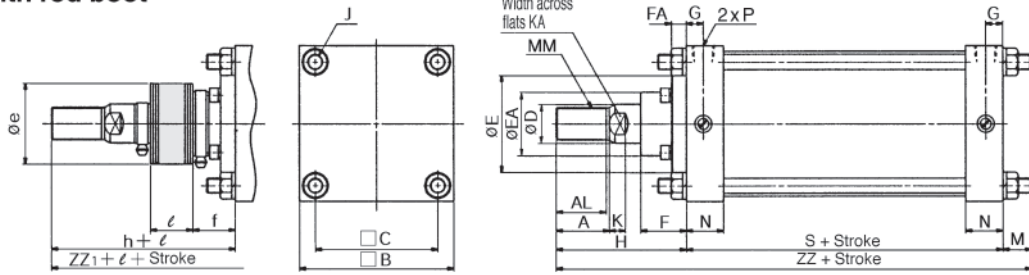

With auto switch/CDS1B

With rod boot

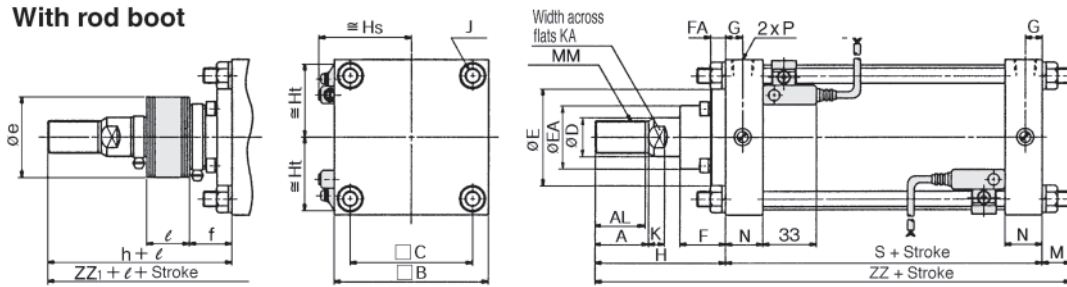

Style	Bore (mm)	Stroke range (mm)*	A	AL	□B	□C	D	E	EA	F	FA	G	J	K	KA	M	MM	N	P	S
Lube	125	to 1000	50	47	145	115	36	90	59	43	14	16	M14 X 1.5	15	31	27	M30 X 1.5	35	1/2	98
Non-lube	140	to 1000	50	47	161	128	36	90	59	43	14	16	M14 X 1.5	15	31	27	M30 X 1.5	35	1/2	98
Air-hydro	160	to 1200	56	53	182	144	40	90	59	43	14	18.5	M16 X 1.5	17	36	30.5	M36 X 1.5	39	3/4	106
Lube Non-lube	180	to 1200	63	60	204	162	45	115	70	48	17	18.5	M18 X 1.5	20	41	35	M40 X 1.5	39	3/4	111
	200	to 1200	63	60	226	182	50	115	74	48	17	18.5	M20 X 1.5	20	46	35	M45 X 1.5	39	3/4	111
	250	to 1200	71	67	277	225	60	140	86	60	20	23	M24 X 1.5	25	56	41.5	M56 X 2	49	1	141
	300	to 1200	80	76	330	270	70	140	96	60	20	23	M30 X 1.5	30	65	51.5	M64 X 2	49	1	146

Style	Bore (mm)	W/o rod boot		W/ rod boot				
		H	ZZ	e	f	h	l	ZZ ₁
Lube	125	110	235	75	40	133	0.2 Stroke	258
Non-lube	140	110	235	75	40	133	0.2 Stroke	258
Air-hydro	160	120	256.5	75	40	141	0.2 Stroke	277.5
Lube Non-lube	180	135	281	85	45	153	0.2 Stroke	299
	200	135	281	90	45	153	0.2 Stroke	299
	250	160	342.5	105	55	176	0.17 Stroke	358.5
	300	175	372.5	115	55	190	0.17 Stroke	387.5

* In case of rod boot style, min. stroke is 30 mm or more.

Style	Bore (mm)	Stroke range (mm)*	S	W/ rod boot	
				W/o rod boot ZZ	W/ rod boot ZZ ₁
Lube	125	to 1000	98	235	258
Non-lube	140	to 1000	98	235	258
Air-hydro	160	to 1200	106	256.5	277.5
Lube	180	to 1200	115	285	303
Non-lube	200	to 998	120	290	308

* Other dimensions are the same as standard style.

** Refer to p.1.14-22 for dimensions of auto switch setting position and mounting height.

*** Refer to p1.14-10 for auto switch min. mountable stroke.

Foot/CS1L

Lube (CS1L), Non-lube (CS1LN), Air-hydro (CS1LH)

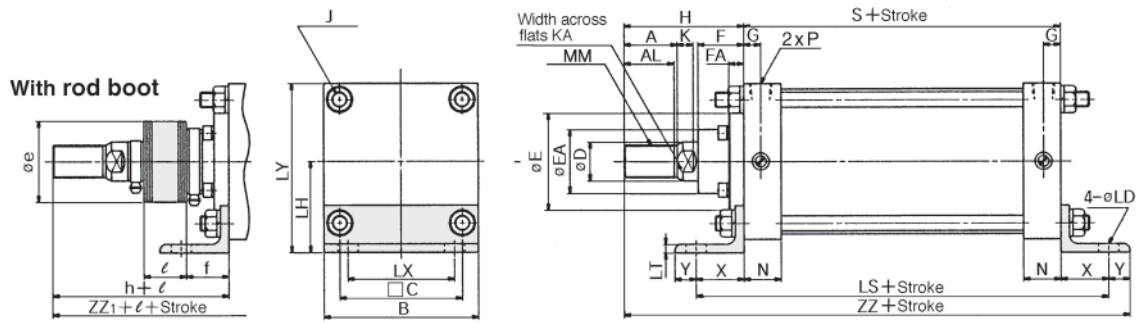

Long stroke

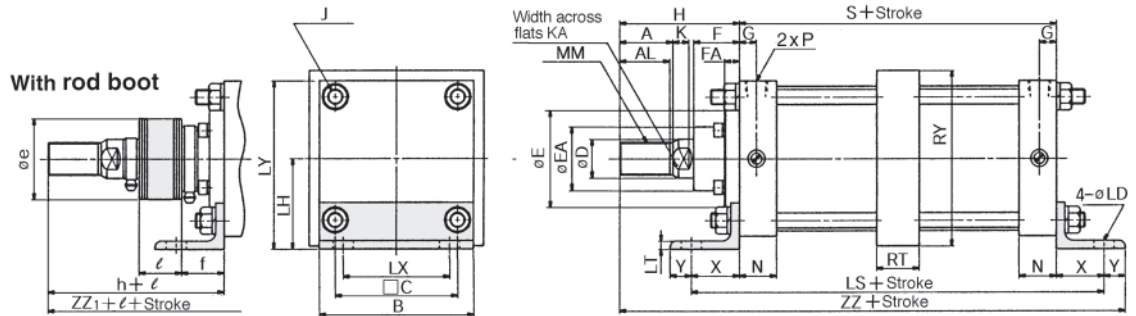

With auto switch/CDS1L

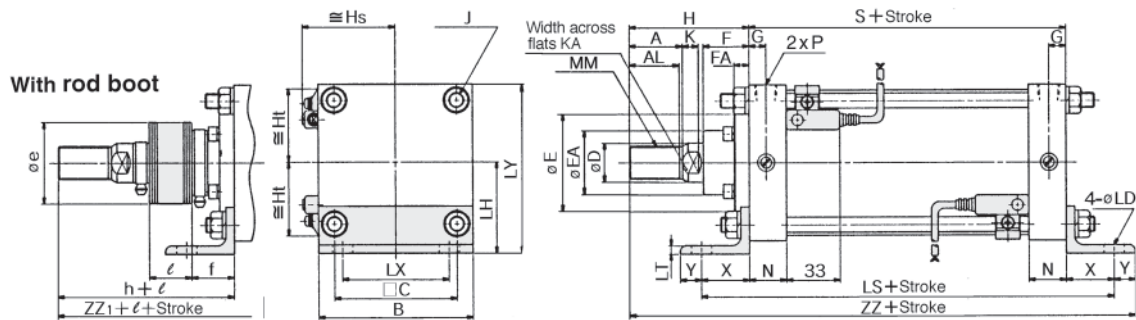

Style	Bore (mm)	Stroke range (mm)*	Long stroke range (mm)	A	AL	B	□C	D	E	EA	F	FA	G	J	K	KA	LD	LH	LS	LT	LX	LY	MM	N	P	RT
Lube	125	to 1400	1401 to 1600	50	47	145	115	36	90	59	43	14	16	M14 X 1.5	15	31	19	85	188	8	100	157.5	M30 X 1.5	35	1/2	36
Non-lube	140	to 1400	1401 to 1600	50	47	161	128	36	90	59	43	14	16	M14 X 1.5	15	31	19	100	188	9	112	180.5	M30 X 1.5	35	1/2	36
Air-hydro	160	to 1400	1401 to 1600	56	53	182	144	40	90	59	43	14	18.5	M16 X 1.5	17	36	19	106	206	9	118	197	M36 X 1.5	39	3/4	45
Lube Non-lube	180	to 1800	1801 to 2000	63	60	204	162	45	115	70	48	17	18.5	M18 X 1.5	20	41	24	125	231	10	132	227	M40 X 1.5	39	3/4	45
	200	to 1800	1801 to 2000	63	60	226	182	50	115	74	48	17	18.5	M20 X 1.5	20	46	24	132	231	10	150	245	M45 X 1.5	39	3/4	45
	250	to 2000	2001 to 2400	71	67	277	225	60	140	86	60	20	23	M24 X 1.5	25	56	29	160	301	12	180	298.5	M56 X 2	49	1	55
	300	to 2000	2001 to 2400	80	76	330	270	70	140	96	60	20	23	M30 X 1.5	30	65	33	200	326	15	212	365	M64 X 2	49	1	55

Style	Bore (mm)	RY	S	X	Y	W/o rod boot		W/ rod boot					
						H	ZZ	e	f	h	l	ZZ ₁	
Lube	125	164	98	45	20	110	273	75	40	133	0.2 Stroke	296	
Non-lube	140	184	98	45	30	110	283	75	40	133	0.2 Stroke	306	
Air-hydro	160	204	106	50	25	120	301	75	40	141	0.2 Stroke	322	
Lube Non-lube	180	228	111	60	30	135	336	85	45	153	0.2 Stroke	354	
	200	257	111	60	30	135	336	90	45	153	0.2 Stroke	354	
	250	325	141	80	40	160	421	105	55	176	0.17 Stroke	437	
	300	390	146	90	40	175	451	115	55	190	0.17 Stroke	466	

* In case of rod boot style, min. stroke is 30 mm or more.

With auto switch/Ø 125 to Ø 200 only

Style	Bore (mm)	Stroke range (mm)	S	LS	W/o rod boot		W/ rod boot	
					ZZ	ZZ ₁		
Lube	125	to 1400	98	188	273	296		
Non-lube	140	to 1400	98	188	283	306		
Air-hydro	160	to 1400	106	206	301	322		
Lube	180	to 1500	115	235	340	358		
Non-lube	200	to 998	120	240	345	363		

* Other dimensions are the same as standard style.

** Refer to p.1.14-22 for dimensions of auto switch setting position and mounting height.

*** Refer to p.1.14-10 for auto switch min. mountable stroke.

- CJ1
- CJP
- CJ2
- CM2
- C85
- C76
- CG1
- MB
- MB1
- CP95
- C95
- C92
- CA1
- CS1**

Series C□S1

Front Flange/CS1F

Lube (CS1F), Non-lube (CS1FN), Air-hydro (CS1FH)

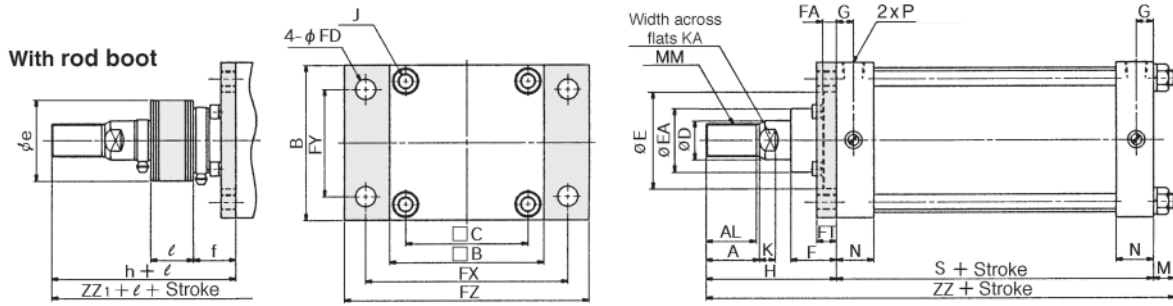

Long stroke

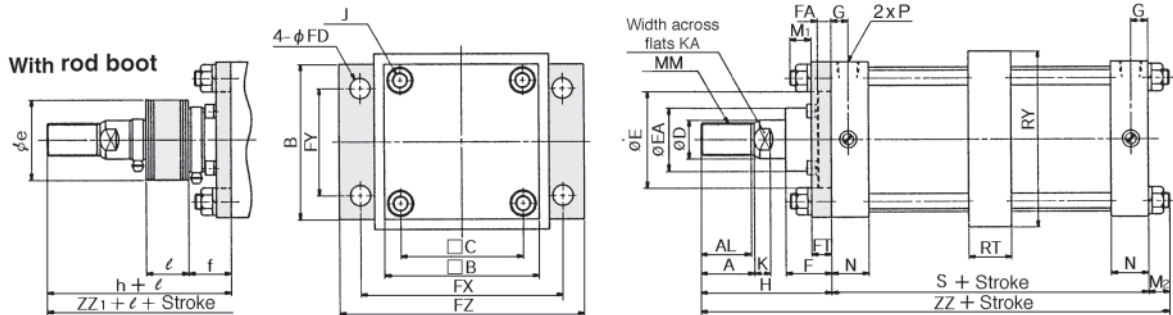

With auto switch/CDS1F

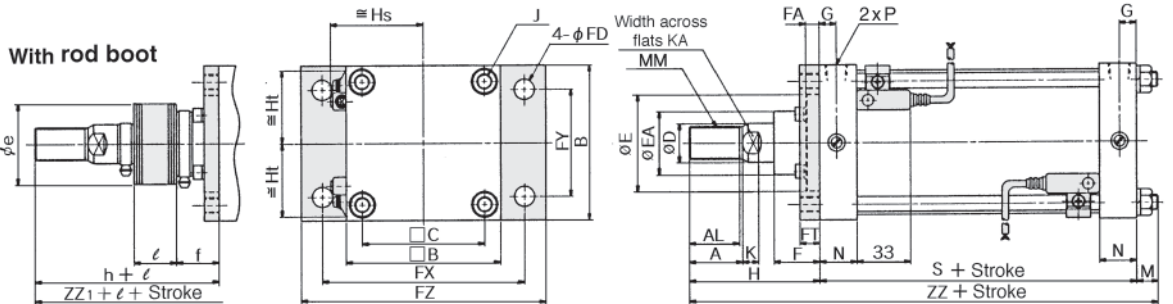

Style	Bore (mm)	Stroke range (mm)*																		W/o rod boot		With rod boot												
			A	AL	B	□B	□C	D	E	EA	F	FA	FD	FT	FX	FY	FZ	G	J	K	KA	M	S	N	P	MM	H	ZZ	e	f	h	l	ZZ1	
Lube	125	to 1400	50	47	145	145	115	36	90	59	43	14	19	14	190	100	230	16	M14 X 1.5	15	31	30	98	35	1/2	M30 X 1.5	110	238	75	40	133			261
Non-lube	140	to 1400	50	47	160	161	128	36	90	59	43	14	19	20	212	112	255	16	M14 X 1.5	15	31	24	98	35	1/2	M30 X 1.5	110	232	75	40	133			255
Air-hydro	160	to 1400	56	53	180	182	144	40	90	59	43	14	19	20	236	118	275	18.5	M16 X 1.5	17	36	26	106	39	3/4	M36 X 1.5	120	252	75	40	141	0.2 X		273
Lube	180	to 1800	63	60	200	204	162	45	115	70	48	17	24	25	265	132	320	18.5	M18 X 1.5	20	41	31	111	39	3/4	M40 X 1.5	135	277	85	45	153			295
	200	to 1800	63	60	225	226	182	50	115	74	48	17	24	25	280	150	335	18.5	M20 X 1.5	20	46	31	111	39	3/4	M45 X 1.5	135	277	90	45	153			295
	250	to 2000	71	67	275	277	225	60	140	86	60	20	29	30	355	180	420	23	M24 X 1.5	25	56	35	141	49	1	M56 X 2	160	336	105	55	176	0.17 X		352
Non-lube	300	to 2000	80	76	330	330	270	70	140	96	60	20	33	30	400	212	475	23	M30 X 1.5	30	65	48	146	49	1	M64 X 2	175	369	115	55	190	Stroke		384

Long stroke

Style	Bore (mm)	Long stroke range (mm)					W/o rod boot		W/ rod boot	
			M1	M2	RT	RY	ZZ	ZZ1		
Lube	125	1401 to 1600	22	22	36	164	230	253		
Non-lube	140	1401 to 1600	19	19	36	184	227	250		
Air-hydro	160	1401 to 1600	22	22	45	204	248	269		
Lube	180	1801 to 2000	26	26	45	228	272	290		
	200	1801 to 2000	26	26	45	257	272	290		
	250	2001 to 2400	30	30	55	325	331	347		
	300	2001 to 2400	36	36	55	390	357	372		

With auto switch/Ø 125 to Ø 200 only

Style	Bore (mm)	Stroke range (mm)	S	W/o rod boot		W/ rod boot	
				ZZ	ZZ1		
Lube	125	to 1400	98	238	261		
Non-lube	140	to 1400	98	232	255		
Air-hydro	160	to 1400	106	252	273		
Lube	180	to 1500	115	281	299		
Non-lube	200	to 998	120	286	304		

* In case of rod boot style, min. stroke is 30 mm or more.

* Other dimensions are the same as standard style.
 ** Refer to p.1.14-22 for dimensions of auto switch setting position and mounting height.
 *** Refer to p.1.14-10 for auto switch min. mountable stroke.

Rear Flange/CS1G

Lube (CS1G), Non-lube (CS1GN), Air-hydro (CS1GH)

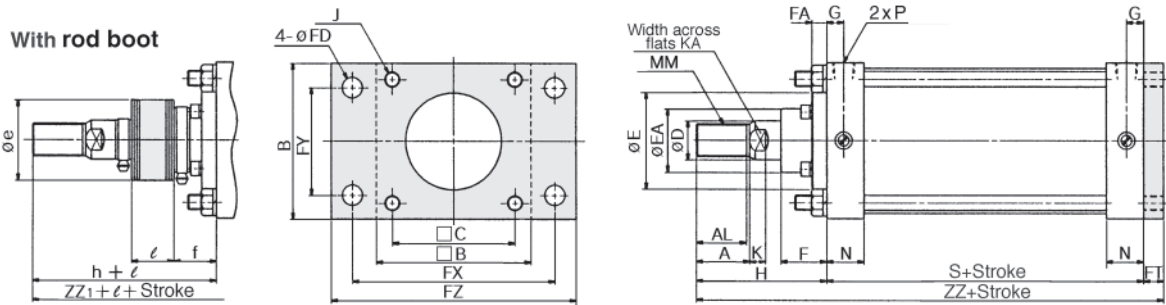

With auto switch/CDS1G

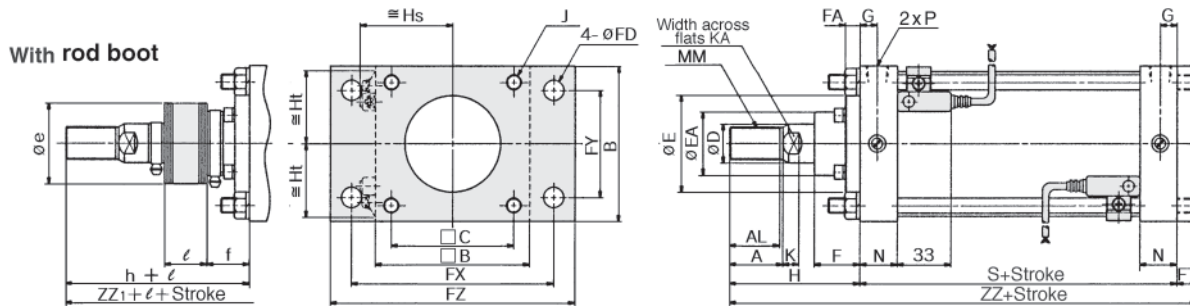

Style	Bore (mm)	Stroke range (mm)*	A	AL	B	□B	□C	D	E	EA	F	FA	FD	FT	FX	FY	FZ	G	J	K	KA	MM	N	P
Lube	125	to 1000	50	47	145	145	115	36	90	59	43	14	19	14	190	100	230	16	M14 X 1.5	15	31	M30 X 1.5	35	1/2
Non-lube	140	to 1000	50	47	160	161	128	36	90	59	43	14	19	20	212	112	255	16	M14 X 1.5	15	31	M30 X 1.5	35	1/2
Air-hydro	160	to 1200	56	53	180	182	144	40	90	59	43	14	19	20	236	118	275	18.5	M16 X 1.5	17	36	M36 X 1.5	39	3/4
Lube	180	to 1200	63	60	200	204	162	45	115	70	48	17	24	25	265	132	320	18.5	M18 X 1.5	20	41	M40 X 1.5	39	3/4
Non-lube	200	to 1200	63	60	225	226	182	50	115	74	48	17	24	25	280	150	335	18.5	M20 X 1.5	20	46	M45 X 1.5	39	3/4
	250	to 1200	71	67	275	277	225	60	140	86	60	20	29	30	355	180	420	23	M24 X 1.5	25	56	M56 X 2	49	1
	300	to 1200	80	76	330	330	270	70	140	96	60	20	33	30	400	212	475	23	M30 X 1.5	30	65	M64 X 2	49	1

Style	Bore (mm)	S	W/o rod boot		W/ rod boot				
			H	ZZ	e	f	h	l	ZZ ₁
Lube	125	98	110	222	75	40	133	0.2 Stroke	245
Non-lube	140	98	110	228	75	40	133	0.2 Stroke	251
Air-hydro	160	106	120	246	75	40	141	0.2 Stroke	267
	180	111	135	271	85	45	153	0.2 Stroke	289
Lube	200	111	135	271	90	45	153	0.2 Stroke	289
Non-lube	250	141	160	331	105	55	176	0.17 Stroke	347
	300	146	175	351	115	55	190	0.17 Stroke	366

* In case of rod boot style, min. stroke is 30 mm or more.

With auto switch/Ø 125 to Ø 200 only (mm)

Style	Bore (mm)	Stroke range (mm)	S	W/o rod boot	W/ rod boot
Lube	125	to 1000	98	222	245
Non-lube	140	to 1000	98	228	251
Air-hydro	160	to 1200	106	246	267
Lube	180	to 1200	115	275	293
Non-lube	200	to 998	120	280	298

* Other dimensions are the same as standard style.

** Refer to p.1.14-22 for dimensions of auto switch setting position and mounting height.

*** Refer to p.1.14-10 for auto switch min. mountable stroke.

CJ1

CJP

CJ2

CM2

C85

C76

CG1

MB

MB1

CP95

C95

C92

CA1

CS1

Series C□S1

Single Clevis/CS1C

Lube (CS1C), Non-lube (CS1CN), Air-hydro (CS1CH)

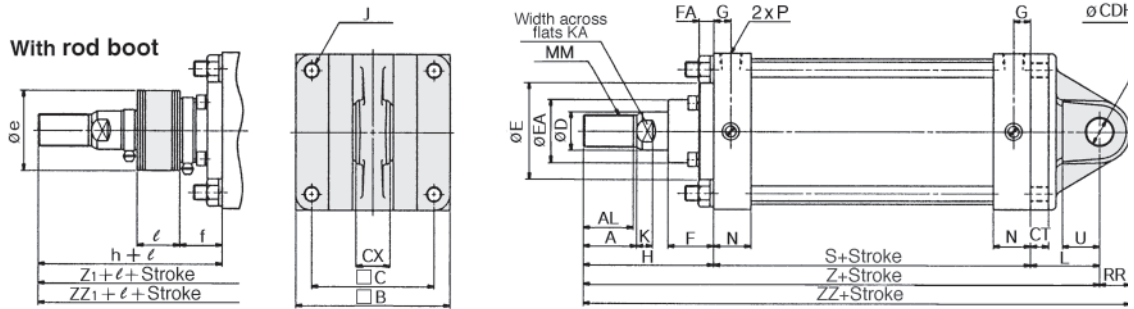

With auto switch/CDS1C

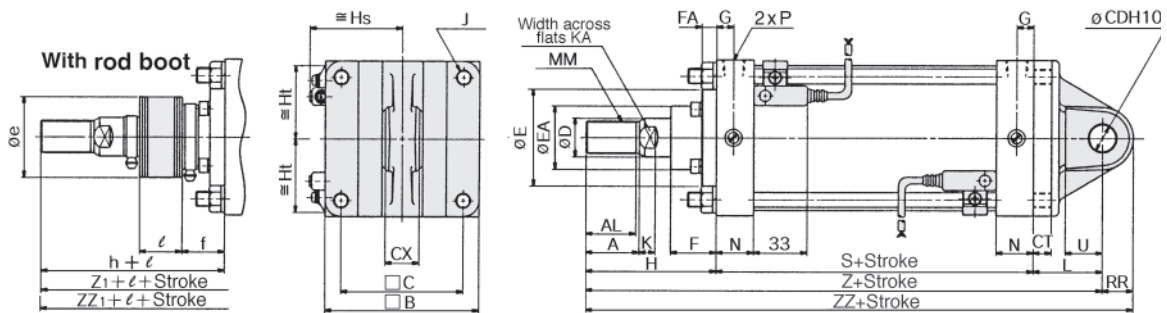

Style	Bore (mm)	Stroke range (mm)*	A	AL	□B	□C	CDH10	CT	CX	D	E	EA	F	FA	G	J	K	KA	L	MM	N	P	RR
Lube	125	to 1000	50	47	145	115	25 ^{+0.084} ₀	17	32 ^{-0.1} _{-0.3}	36	90	59	43	14	16	M14 X 1.5	15	31	65	M30 X 1.5	35	1/2	29
Non-lube	140	to 1000	50	47	161	128	28 ^{+0.084} ₀	17	36 ^{-0.1} _{-0.3}	36	90	59	43	14	16	M14 X .5	15	31	75	M30 X 1.5	35	1/2	32
Air-hydro	160	to 1200	56	53	182	144	32 ^{+0.100} ₀	20	40 ^{-0.1} _{-0.3}	40	90	59	43	14	18.5	M16 X 1.5	17	36	80	M36 X 1.5	39	3/4	36
Lube	180	to 1200	63	60	204	162	40 ^{+0.100} ₀	23	50 ^{-0.1} _{-0.3}	45	115	70	48	17	18.5	M18 X 1.5	20	41	90	M40 X 1.5	39	3/4	44
Non-lube	200	to 1200	63	60	226	182	40 ^{+0.100} ₀	25	50 ^{-0.1} _{-0.3}	50	115	74	48	17	18.5	M20 X 1.5	20	46	90	M45 X 1.5	39	3/4	44
	250	to 1200	71	67	277	225	50 ^{+0.100} ₀	30	63 ^{-0.1} _{-0.3}	60	140	86	60	20	23	M24 X 1.5	25	56	110	M56 X 2	49	1	55
	300	to 1200	80	76	330	270	63 ^{+0.120} ₀	37	80 ^{-0.1} _{-0.3}	70	140	96	60	20	23	M30 X 1.5	30	65	130	M64 X 2	49	1	68

Style	Bore (mm)	S	U	(mm)									
				W/o rod boot			W/rod boot						
				H	Z	ZZ	e	f	h	l	Z1	ZZ1	
Lube	125	98	35	110	273	302	75	40	133	0.2 Stroke	296	325	
Non-lube	140	98	40	110	283	315	75	40	133	0.2 Stroke	306	338	
Air-hydro	160	106	45	120	306	342	75	40	141	0.2 Stroke	327	363	
	180	111	50	135	336	380	85	45	153	0.2 Stroke	354	398	
Lube	200	111	50	135	336	380	90	45	153	0.2 Stroke	354	398	
Non-lube	250	141	65	160	411	466	105	55	176	0.17 Stroke	427	482	
	300	146	80	175	451	519	115	55	190	0.17 Stroke	466	534	

* In case of rod boot style, min. stroke is 30 mm or more.

With auto switch/Ø 125 to Ø 200 only (mm)

Style	Bore (mm)	Stroke range (mm)	S	W/o rod boot		W/ rod boot	
				Z	ZZ	Z1	ZZ1
Lube	125	to 1000	98	273	302	296	325
Non-lube	140	to 1000	98	283	315	306	338
Air-hydro	160	to 1200	106	306	342	327	363
Lube	180	to 1200	115	340	384	358	402
Non-lube	200	to 998	120	345	389	363	407

* Other dimensions are the same as standard style.

** Refer to p.1.14-22 for dimensions of auto switch setting position and mounting height.

*** Refer to p.1.14-10 for auto switch min. mountable stroke.

Double Clevis/CS1D

Lube (CS1D), Non-lube (CS1DN), Air-hydro (CS1DH)

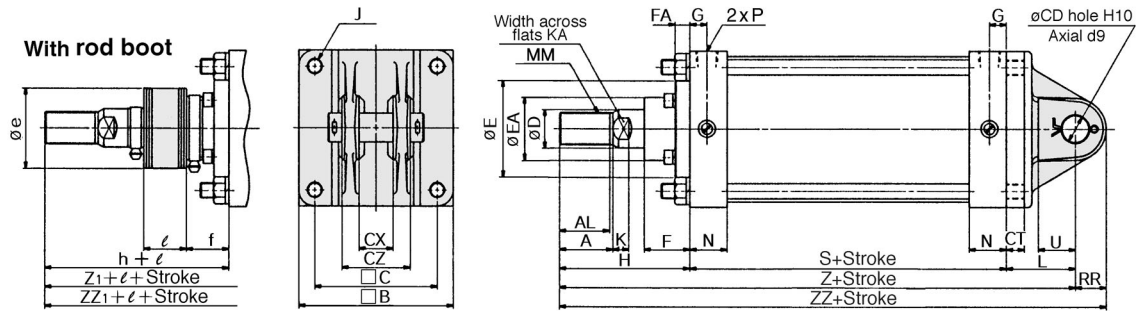

With auto switch/CDS1D

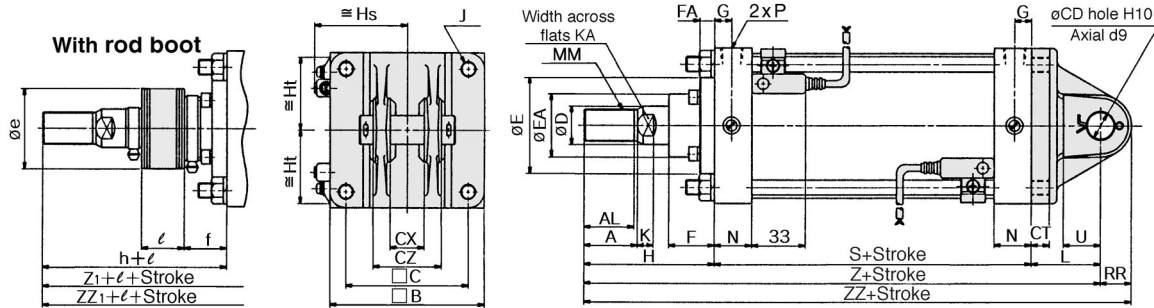

CJ1

CJP

CJ2

CM2

C85

C76

CG1

MB

MB1

CP95

C95

C92

CA1

CS1

Style	Bore (mm)	Stroke range (mm)*	A	AL	□B	□C	CD _{H10}	CT	CX	CZ	D	E	EA	F	FA	G	J	K	KA	L	MM	N	P	RR
Lube	125	to 1000	50	47	145	115	25 ^{+0.084} ₀	17	32 ^{+0.3} _{+0.1}	64 ⁰ _{-0.2}	36	90	59	43	14	16	M14 X 1.5	15	31	65	M30 X 1.5	35	1/2	29
Non-lube	140	to 1000	50	47	161	128	28 ^{+0.084} ₀	17	36 ^{+0.3} _{+0.1}	72 ⁰ _{-0.2}	36	90	59	43	14	16	M14 X 1.5	15	31	75	M30 X 1.5	35	1/2	32
Air-hydro	160	to 1200	56	53	182	144	32 ^{+0.100} ₀	20	40 ^{+0.3} _{+0.1}	80 ⁰ _{-0.2}	40	90	59	43	14	18.5	M16 X 1.5	17	36	80	M36 X 1.5	39	3/4	36
Lube	180	to 1200	63	60	204	162	40 ^{+0.100} ₀	23	50 ^{+0.3} _{+0.1}	100 ^{-0.1} _{-0.3}	45	115	70	48	17	18.5	M18 X 1.5	20	41	90	M40 X 1.5	39	3/4	44
Non-lube	200	to 1200	63	60	226	182	40 ^{+0.100} ₀	25	50 ^{+0.3} _{+0.1}	100 ^{-0.1} _{-0.3}	50	115	74	48	17	18.5	M20 X 1.5	20	46	90	M45 X 1.5	39	3/4	44
	250	to 1200	71	67	277	225	50 ^{+0.100} ₀	30	63 ^{+0.3} _{+0.1}	126 ^{-0.1} _{-0.3}	60	140	86	60	20	23	M24 X 1.5	25	56	110	M56 X 2	49	1	55
	300	to 1200	80	76	330	270	63 ^{+0.120} ₀	37	80 ^{+0.3} _{+0.1}	160 ^{-0.1} _{-0.3}	70	140	96	60	20	23	M30 X 1.5	30	65	130	M64 X 2	49	1	68

Style	Bore (mm)	S	U	W/o rod boot			W/rod boot					
				H	Z	ZZ	e	f	h	l	Z ₁	ZZ ₁
Lube	125	98	35	110	273	302	75	40	133	0.2 Stroke	296	325
Non-lube	140	98	40	110	283	315	75	40	133	0.2 Stroke	306	338
Air-hydro	160	106	45	120	306	342	75	40	141	0.2 Stroke	327	363
Lube	180	111	50	135	336	380	85	45	153	0.2 Stroke	354	398
Non-lube	200	111	50	135	336	380	90	45	153	0.2 Stroke	354	398
	250	141	65	160	411	466	105	55	176	0.17 Stroke	427	482
	300	146	80	175	451	519	115	55	190	0.17 Stroke	466	534

* In case of rod boot style, min. stroke is 30 mm or more.

With auto switch/Ø 125 to Ø 200 only (mm)

Style	Bore (mm)	Stroke range (mm)	S	W/o rod boot		W/ rod boot	
				Z	ZZ	Z ₁	ZZ ₁
Lube	125	to 1000	98	273	302	296	325
Non-lube	140	to 1000	98	283	315	306	338
Air-hydro	160	to 1200	106	306	342	327	363
Lube	180	to 1200	115	340	384	358	402
Non-lube	200	to 998	120	345	389	363	407

* Other dimensions are the same as standard style.

** Refer to p.1.14-22 for dimensions of auto switch setting position and mounting height.

*** Refer to p.1.14-10 for auto switch min. mountable stroke.

Series C□S1

Centre Trunnion/CS1T

Lube (CS1T), Non-lube (CS1TN), Air-hydro (CS1TH)

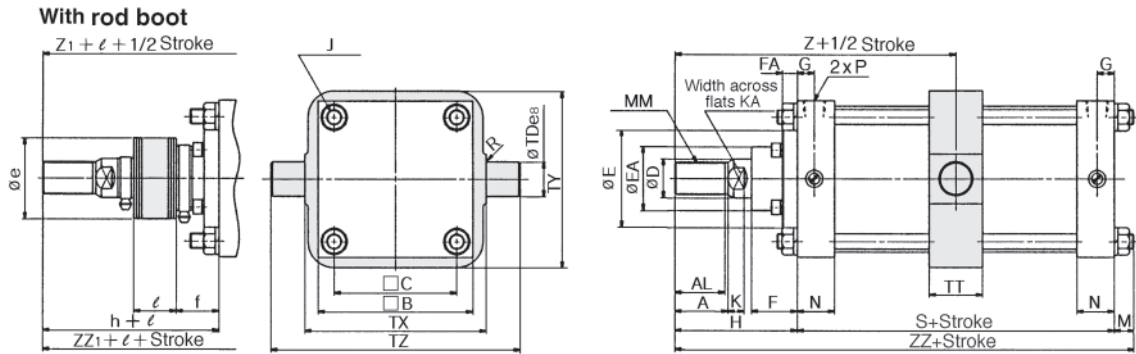

With auto switch/CDS1T

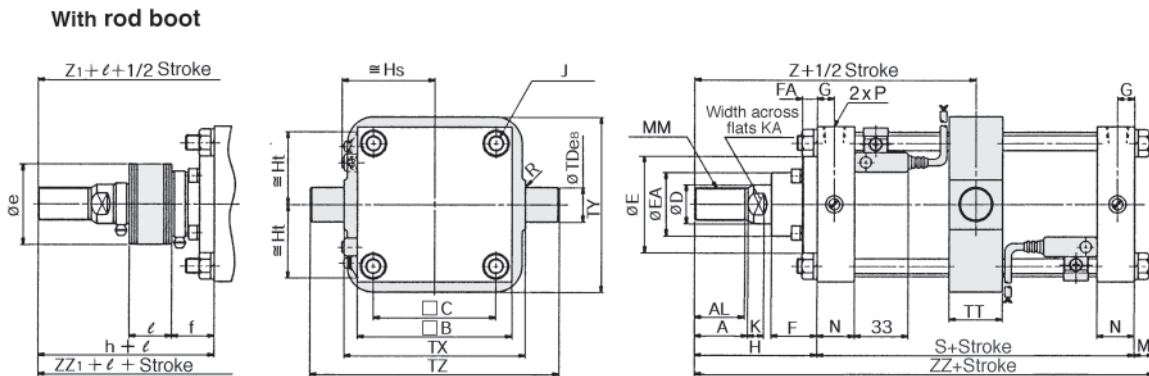

Style	Bore (mm)	Stroke range (mm)*	A	AL	□B	□C	D	E	EA	F	FA	G	J	K	KA	M	MM	N	P	R	S	TDes	TT	TX
Lube	125	25 to 1000	50	47	145	115	36	90	59	43	14	16	M14 X 1.5	15	31	19	M30 X 1.5	35	1/2	1	98	32 ^{-0.050} _{-0.089}	50	170
Non-lube	140	30 to 1000	50	47	161	128	36	90	59	43	14	16	M14 X 1.5	15	31	19	M30 X 1.5	35	1/2	1.5	98	36 ^{-0.050} _{-0.089}	55	190
Air-hydro	160	35 to 1200	56	53	182	144	40	90	59	43	14	18.5	M16 X 1.5	17	36	22	M36 X 1.5	39	3/4	1.5	106	40 ^{-0.050} _{-0.089}	60	212
Lube	180	30 to 1200	63	60	204	162	45	115	70	48	17	18.5	M18 X 1.5	20	41	26	M40 X 1.5	39	3/4	2	111	45 ^{-0.050} _{-0.089}	59	236
Non-lube	200	30 to 1200	63	60	226	182	50	115	74	48	17	18.5	M20 X 1.5	20	46	26	M45 X 1.5	39	3/4	2	111	45 ^{-0.050} _{-0.089}	59	265
	250	30 to 1200	71	67	277	225	60	140	86	60	20	23	M24 X 1.5	25	56	30	M56 X 2	49	1	3	141	56 ^{-0.060} _{-0.106}	69	335
	300	35 to 1200	80	76	330	270	70	140	96	60	20	23	M30 X 1.5	30	65	36	M64 X 2	49	1	4	146	67 ^{-0.060} _{-0.106}	79	400

Style	Bore (mm)	TY	TZ	(mm)									
				W/o rod boot			W/rod boot						
				H	Z	ZZ	e	f	h	l	Z ₁	ZZ ₁	
Lube	125	164	234	110	159	227	75	40	133	0.2 Stroke	182	250	
Non-lube	140	184	262	110	159	227	75	40	133	0.2 Stroke	182	250	
Air-hydro	160	204	292	120	173	248	75	40	141	0.2 Stroke	194	269	
Lube	180	228	326	135	190.5	272	85	45	153	0.2 Stroke	208.5	290	
Non-lube	200	257	355	135	190.5	272	90	45	153	0.2 Stroke	208.5	290	
	250	325	447	160	230.5	331	105	55	176	0.17 Stroke	246.5	347	
	300	390	534	175	248	357	115	55	190	0.17 Stroke	263	372	

* In case of rod boot style, min. stroke is 30 mm or more.
 (In case of rod boot style of bore size Ø 160 and Ø 300, min. stroke is 35 mm or more.)

Style	Bore (mm)	Stroke range (mm)	S	(mm)			
				W/o rod boot		W/ rod boot	
				Z	ZZ	Z ₁	ZZ ₁
Lube	125	to 1000	98	159	227	182	250
Non-lube	140	to 1000	98	159	227	182	250
Air-hydro	160	to 1200	106	173	248	194	269
Lube	180	to 1200	115	192.5	276	210.5	294
Non-lube	200	to 998	120	195	281	213	299

* Other dimensions are the same as standard style.
 ** Refer to p.1.14-22 for dimensions of auto switch setting position and mounting height.
 *** Refer to p.1.14-10 for auto switch min. mountable stroke.

Air Cylinder Series CS1 Accessory Dimensions

Accessories

I type single knuckle joint*

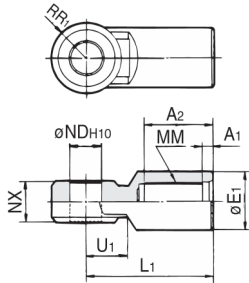

Material: Cast iron

Part No.	Bore (mm)	A ₁	A ₂	E ₁	L ₁	MM	ND _{H10}	NX	RR ₁	U ₁
I-12	125	8	54	46	100	M30 X 1.5	25 ^{+0.084} ₀	32 ^{-0.1} _{-0.3}	27	33
I-14	140	8	54	48	105	M30 X 1.5	28 ^{+0.084} ₀	36 ^{-0.1} _{-0.3}	30	39
I-16	160	8	60	55	110	M36 X 1.5	32 ^{+0.1} ₀	40 ^{-0.1} _{-0.3}	34	39
I-18	180	8	67	70	125	M40 X 1.5	40 ^{+0.1} ₀	50 ^{-0.1} _{-0.3}	42.5	44
I-20	200	8	67	70	125	M45 X 1.5	40 ^{+0.1} ₀	50 ^{-0.1} _{-0.3}	42.5	44
I-25	250	9	75.5	86	160	M56 X 2	50 ^{+0.1} ₀	63 ^{-0.1} _{-0.3}	53	66
I-30	300	9	84.5	105	175	M64 X 2	63 ^{+0.12} ₀	80 ^{-0.1} _{-0.3}	66	71

Y type double knuckle joint *

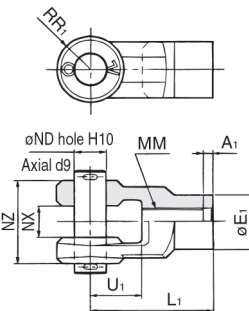

Material: Cast iron

Part No.	Bore (mm)	A ₁	E ₁	L ₁	MM	ND _{H10}	NX	NZ	RR ₁	U ₁
Y-12	125	8	46	100	M30 X 1.5	25 ^{+0.084} ₀	32 ^{+0.3} _{+0.1}	64 ^{-0.1} _{-0.3}	27	42
Y-14	140	8	48	105	M30 X 1.5	28 ^{+0.084} ₀	36 ^{+0.3} _{+0.1}	72 ^{-0.1} _{-0.3}	30	47
Y-16	160	8	55	110	M36 X 1.5	32 ^{+0.1} ₀	40 ^{+0.3} _{+0.1}	80 ^{-0.1} _{-0.3}	34	46
Y-18	180	8	70	125	M40 X 1.5	40 ^{+0.1} ₀	50 ^{+0.3} _{+0.1}	100 ^{-0.1} _{-0.3}	42.5	54
Y-20	200	8	70	125	M45 X 1.5	40 ^{+0.1} ₀	50 ^{+0.3} _{+0.1}	100 ^{-0.1} _{-0.3}	42.5	54
Y-25	250	9	86	160	M56 X 2	50 ^{+0.1} ₀	63 ^{+0.3} _{+0.1}	126 ^{-0.1} _{-0.3}	53	81
Y-30	300	9	105	175	M64 X 2	63 ^{+0.12} ₀	80 ^{+0.3} _{+0.1}	160 ^{-0.1} _{-0.3}	66	87

* Use a single knuckle joint or a double knuckle joint individually.
(Screw it entirely over the rod end threads and tighten it.)

* To use a single knuckle joint or a double knuckle joint concurrently with a rod end nut, extend dimensions A/H.
(To extend dimensions A/H, refer to the table below, and specify the product as Order Made -XAO.)

Single/Double knuckle joint mounting

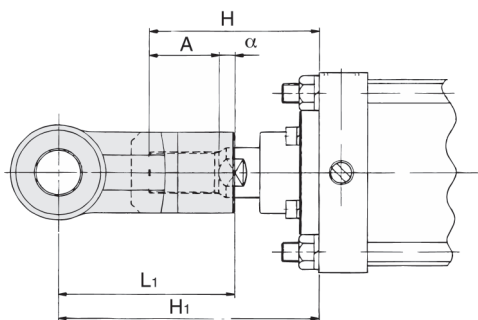

Bore (mm)	Symbol	H	A	α	L ₁	H ₁	Applicable knuckle joint part No.	
							I type single knuckle	Y type double knuckle
125		110	50	3.5	100	156.5	I-12	Y-12
140		110	50	3.5	105	161.5	I-14	Y-14
160		120	56	3.5	110	170.5	I-16	Y-16
180 / 200		135	63	3.5	125	193.5	I-18, I-20	Y-18, Y-20
250		160	71	3.5	160	245.5	I-25	Y-25
300		175	80	3.5	175	266.5	I-30	Y-30

Knuckle pin, Clevis pin

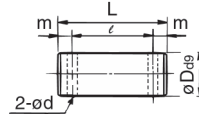

Material: Carbon steel

Part No.	Bore (mm)	Dd ₉	L	l	m	d (Drill through)	Cotter pin
IY-12	125	25 ^{-0.065} _{-0.117}	79.5	69.5	5	4	ø4 X 40
IY-14	140	28 ^{-0.065} _{-0.117}	86.5	76.5	5	4	ø4 X 40
IY-16	160	32 ^{-0.080} _{-0.142}	94.5	84.5	5	4	ø4 X 40
IY-18	180/200	40 ^{-0.080} _{-0.142}	115	105	5	4	ø4 X 55
IY-25	250	50 ^{-0.080} _{-0.142}	144	132	6	5	ø5 X 65
IY-30	300	63 ^{-0.100} _{-0.174}	178	166	6	5	ø5 X 80

Rod end nut

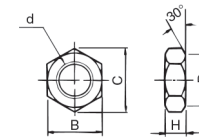

Material: Rolled steel

Part No.	Bore (mm)	d	H	B	C	D
NT-12	125/140	M30 X 1.5	18	46	53.1	44
NT-16	160	M36 X 1.5	21	55	63.5	53
NT-18	180	M40 X 1.5	23	60	69.3	57
NT-20	200	M45 X 1.5	27	70	80.8	67
NT-25	250	M56 X 2	34	85	98.1	82
NT-30	300	M64 X 2	38	95	110.0	92

A, H dimensions at using both single/double knuckle joint and rod end nut

Bore (mm)	A	H
125	65	125
140	65	125
160	76	140
180	83	155
200	88	160
250	106	195
300	115	210

Air Cylinder/Double Rod Series CS1W

Lube, Non-lube/Ø 125, Ø 140, Ø 160, Ø 180, Ø 200, Ø 250, Ø 300
Air-hydro/Ø 125, Ø 140, Ø 160

How to Order

Standard CS1W L [] [] 125 [] - 100 [] - []

With auto switch CDS1W L [] [] 125 [] - 100 [] - M9BW [] - []

Built in magnet (Ø 125 to Ø 200) (Built-in magnet)

Double rod type

Mounting

B	Basic type
L	Foot type
F	Rod side flange type
T	Center trunnion type

Tubing material

Symbol	Bore size (mm)	Tubing material	Stroke range (mm)	
			Without switch	With switch
—	125, 140	Aluminum tube	1000 or less	1000 or less
			1200 or less	1200 or less
	180	Steel tube	1200 or less	1200 or less
			1200 or less	998 or less
			1200 or less	—
F	125, 140	Steel tube	1000 or less	1000 or less
			1200 or less	1200 or less

Port thread type

—	Rc
TN	NPT
TF	G

Bore size

Lube, Non-lube		Air-hydro	
125	125 mm	125	125 mm
140	140 mm	140	140 mm
160	160 mm	160	160 mm
180	180 mm	—	—
200	200 mm	—	—
250*	250 mm	—	—
300*	300 mm	—	—

* It is not available with auto switch.

Type

—	Lube
N	Non-lube
H	Air-hydro

Number of auto switches

—	2 pcs.
3	3 pcs.
S	1 pc.
n	"n" pcs.

Made to Order (Refer to page 1.14-23 for details.)

Auto switch

—	Without auto switch
---	---------------------

* Refer to the table below for the applicable auto switch model.

Suffix for cylinder

Rod boot in one side	J	Nylon tarpaulin
	K	Heat resistant tarpaulin
Rod boot in both sides	JJ	Nylon tarpaulin
	KK	Heat resistant tarpaulin
Cushion	N	Without cushion
	R	With cushion in rod side
	H	With cushion in head side
	—	With cushion in both sides (Air-hydro type has no cushion.)

* If specifying more than one symbol, indicate them in alphabetically.
** Air-hydro type has no cushion. No symbol indicates no cushion.

Cylinder stroke (mm)

Built-in magnet cylinder model

If a built-in magnet cylinder without auto switch is required, there is no need to enter the symbol for auto switch. (Example) CDS1WB125-100

Applicable Auto Switches/Refer to auto switch guide for further information on auto switches.

Type	Special function	Electrical entry	Indicator light	Wiring (Output)	Load voltage		Auto switch model		Lead wire length (m)				Pre-wired connector	Applicable load			
					DC	AC	Tie-rod mounting	Band mounting	0.5 (—)	1 (M)	3 (L)	5 (Z)		IC circuit	Relay, PLC		
Solid state auto switch	—	Grommet	No	3-wire (NPN)	24 V	5 V, 12 V	—	M9N	●	●	●	○	—			—	—
				3-wire (PNP)				M9P	●	●	●	○					
		Terminal conduit	No	2-wire	24 V	5 V, 12 V	—	M9B	●	●	●	○	—	—	—		
				3-wire (NPN)				—	G39	—	—	—				—	—
	Diagnostic indication (2-color indicator)	Grommet	Yes	3-wire (NPN)	24 V	5 V, 12 V	—	M9NW	●	●	●	○	—	—	—		
				3-wire (PNP)				M9PW	●	●	●	○					
				2-wire				M9BW	●	●	●	○					
				3-wire (NPN)				M9NA *1	○	○	●	○					
				3-wire (PNP)				M9PA *1	○	○	●	○					
				2-wire				M9BA *1	○	○	●	○					
Water resistant (2-color indicator)	Grommet	No	3-wire (NPN)	24 V	5 V, 12 V	—	F59F	●	—	●	○	—	—	—			
			3-wire (PNP)				P3DWA	●	—	●	○						
With diagnostic output (2-color indicator)	Grommet	No	4-wire (NPN)	24 V	5 V, 12 V	—	—	●	—	●	○	—	—	—			
			2-wire (Non-polar)				—	●	—	●	○						
Reed auto switch	—	Grommet	Yes	3-wire (NPN equivalent)	24 V	5 V	—	A96	●	—	●	—	—	—	—		
								A93	●	●	●	—					
								A90	●	—	●	—					
								A54	●	—	●	—					
								A64	●	—	●	—					
		Terminal conduit	No	2-wire	24 V	12 V	100 V, 200 V	100 V or less	—	A33	—	—	—	—	—	—	—
										A34	—	—	—	—			
										A44	—	—	—	—			
										—	—	—	—	—			
										—	—	—	—	—			
DIN terminal	Yes	2-wire	24 V	100 V, 200 V	200 V or less	—	—	—	—	—	—	—	—	—			
							—	—	—	—	—						
Diagnostic indication (2-color indicator)	Grommet	No	2-wire	24 V	100 V, 200 V	100 V or less	—	A59W	●	—	●	—	—	—	—		
								—	—	—	—	—					

*1 Water resistant type auto switches can be mounted on the above models, but in such case SMC cannot guarantee water resistance. Consult with SMC regarding water resistant types with the above model numbers.

* Lead wire length symbols: 0.5 m — (Example) M9NW 3 m L (Example) M9NWL
1 m M (Example) M9NWM 5 m Z (Example) M9NWZ

* Solid state auto switches marked with "○" are produced upon receipt of order.

* Since there are other applicable auto switches than listed above, refer to page 1.14-36 for details.

* For details about auto switches with pre-wired connector, refer to auto switch guide.

* D-A9□/M9□/M9□W/M9□A/P3DWA□ auto switches are shipped together (not assembled). (Only auto switch mounting brackets are assembled before shipped.)

Air Cylinder/Double Rod **Series CS1W**

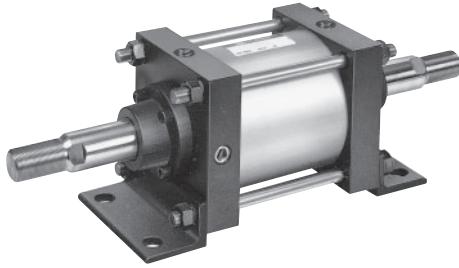

⚠ Precautions

Be sure to read before handling.
Refer to p.0-39 to 0-43 for Safety Instructions
and common precautions.

Symbol
Air cushion

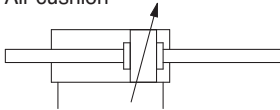

Made to Order Specifications

Symbol	Specifications
-XA□	Change of rod end shape
-XB6	Heat-resistant cylinder (-10 to 150 °C)
-XC4	With heavy duty scraper
-XC5	Heat resistant cylinder (110 °C)
-XC6	Piston rod and rod end nut made of stainless steel
-XC14	Change of trunnion bracket mounting position
-XC15	Change of tie-rod length
-XC30	Rod side trunnion
-XC35	With coil scraper

Major Material and Surface Treatments

Description	Material	Note
Cover	Rolled steel plate	Black coated
Tube*	Aluminum alloy	Hard anodized
	Carbon steel tube	Hard chrome plated
	Carbon steel tube	Hard chrome plated
Sliding seals	NBR	JIS B2401 O ring*
	NBR	PNY, NLP
	NBR	SKY, RPS
Piston rod	Carbon steel tube ^{Note)}	Hard chrome plated
Piston	Cast iron (With auto switch, aluminum alloy casting)	Chromated (In case of aluminum alloy cast)
	Aluminum alloy cast (Steel tubing: Cast iron)	Chromated (In case of aluminum alloy cast)
	Aluminum alloy cast (Steel tubing: Cast iron)	Chromated (In case of aluminum alloy cast)

* In case of an auto switch with bore sizes of Ø 180 and Ø 200, tube material is aluminum alloy (hard anodized). Piston seal is NLP.



Specifications

Style	Lube/Non-lube	Air-hydro
Fluid	Air	Turbine oil
Proof pressure	1.57 MPa	
Max. operating pressure	0.97 MPa	0.97 MPa
Min. operating pressure	0.05 MPa	0.06 MPa
Piston speed	50 to 500 mm/s	0.5 to 200 mm/s
Cushion	With	Without
Ambient and fluid temperature	No switch	0 to 70 °C (No condensation)
	With switch	0 to 60 °C (No condensation)
Thread tolerance	JIS 2 class	
Stroke length tolerance	250 or less: $^{+1.0}_0$ 251 to 1,000: $^{+1.4}_0$ 1,001 to 1,200: $^{+1.8}_0$	
Mounting	Basic, Foot, Front flange, Center trunnion	

Weight/Aluminum tube: Lube style (Non-lube, Air-hydro style) (kg)

Bore size (mm)		Ø 125	Ø 140	Ø 160
Basic weight	Basic	16.51 (15.28)	19.62 (18.12)	26.65 (24.79)
	Foot	18.14 (16.91)	22.14 (20.64)	29.45 (27.59)
	Front flange	19.19 (17.96)	24.62 (23.12)	33.04 (31.18)
	Trunnion	20.64 (19.41)	25.35 (23.85)	34.05 (32.19)
Additional weight per 100stroke		2.57	2.76	3.38
Accessory	Single knuckle joint	0.91	1.16	1.56
	Double knuckle joint (Knuckle pin, Cotter pin)	1.37	1.81	2.48
	Rod end nut	0.16	0.16	0.23

* () shows non-lube and air-hydro style.

Calculation method: (Example) **CS1WL125-500**

- Basic weight 18.14 (Foot style, Ø 125)
 - Additional weight 2.57/100 Stroke
 - Cylinder stroke 500 Stroke
- 18.14+2.57 X 500/100= 30.99 kg

Weight/Steel tubing

Bore size (mm)		Ø 125	Ø 140	Ø 160	Ø 180	Ø 200	Ø 250	Ø 300
Basic weight	Basic	16.85	20.03	27.12	36.90	45.79	85.36	122.39
	Foot	18.48	22.55	29.92	41.10	50.67	94.86	139.67
	Front flange	19.53	25.03	33.51	46.73	57.70	107.20	152.59
	Trunnion	20.98	25.76	34.52	47.52	59.78	113.20	162.82
Additional weight per 100stroke		3.46	3.81	4.57	6.20	7.29	11.30	15.17
Accessory	Single knuckle joint	0.91	1.16	1.56	3.07	2.90	5.38	10.82
	Double knuckle joint (Knuckle pin, Cotter pin)	1.37	1.81	2.48	4.74	4.59	9.22	17.17
	Rod end nut	0.16	0.16	0.23	0.32	0.85	1.26	1.43

Precautions



Refer to p.1.14-6 for precautions.

CJ1

CJP

CJ2

CM2

C85

C76

CG1

MB

MB1

CP95

C95

C92

CA1

CS1

Series CS1W

Rod Boot Materials

Symbol	Material	Max. ambient temp
J	Nylon tarpaulin	60 °C
K	Heat resistant tarpanlin	110 °C*

* Max. ambient temperature for the rod boot itself

Accessories

	Mounting	Basic	Foot	Front flange	Center trunnion
Accessory	Rod end nut	●	●	●	●
	Single knuckle joint	●	●	●	●
	Double knuckle joint (With knuckle pin/cotter pin)	●	●	●	●
	Rod boot	●	●	●	●

Mounting Bracket

Bore size (mm)	125	140	160	180	200	250	300
Foot*	CS1W-L12	CS1W-L14	CS1W-L16	CS1W-L18	CS1W-L20	CS1W-L25	CS1W-L30
Flange	CS1-F12	CS1-F12	CS1-F16	CS1-F18	CS1-F20	CS1-F25	CS1-F30

* Order 2 foot brackets for one cylinder.

Auto Switch Mounting Bracket

Auto switch model	Bore size (mm)				
	125	140	160	180	200
D-A5/A59W/F5□/J5□/F5NT D-F5□W/J59W/F5BA/F5□F	BT-12	BT-12	BT-16	BT-18A	BT-20
D-A3/A44/G39/K39	BS1-125	BS1-140	BS1-160	BS1-180	BS1-200



* Stainless mounting screw set

A set of following stainless steel mounting screws (including a set screw) is attached. (A switch mounting band is not attached. Please order the band separately.)

BBA1: D-A5/A6/F5/J5

"D-F5BA" switch is set on the cylinder with the screws above when shipped.

When a switch only is shipped, "BBA1" screw is attached.

Double Acting Double Rod Style/Replacement Parts (Seal kits)

When ordering the replacement parts (seal kits) for Series CS1W double rod style cylinder, indicate the order number listed in the table on the right. Each set of replacement parts contains the following: wiper ring, rod seal, piston seal, valve seal, tube gasket, and push plate gasket (for 1 cylinder).

Lube style

Bore (mm)	Kit No.	Wiper ring	Rod seal	Piston seal	Valve seal	Tube gasket	Holder plate gasket
125	CS1W-125A-PS	SDR-36	P36	P115	P7	C120	G55
140	CS1W-140A-PS	SDR-36	P36	P130	P7	C135	G55
160	CS1W-160A-PS	SDR-40	P40	P150	P7	C155	G55
180	CS1W-180A-PS	SDR-45	P45	P165	P7	C175	G65
200	CS1W-200A-PS	SDR-50	P50A	P185	P7	C195	G65
250	CS1W-250A-PS	SDR-60	P60	P235	P7	CS160-1618-G4	G80
300	CS1W-300A-PS	SDR-70	P70	P285	P7	CS160-1618-G5	G90

Non-lube style/Non-lube style with auto switch

Bore (mm)	Kit No.	Wiper ring	Rod seal	Piston seal	Valve seal	Tube gasket	Holder plate gasket
125	CS1WN125A-PS	SDR-36	PNY-36	NLP-125A	P7	C120	G55
140	CS1WN140A-PS	SDR-36	PNY-36	NLP-140A	P7	C135	G55
160	CS1WN160A-PS	SDR-40	PNY-40	NLP-160A	P7	C155	G55
180	CS1WN180A-PS	SDR-45	PNY-45	NLP-180A	P7	C175	G65
200	CS1WN200A-PS	SDR-50	PNY-50	NLP-200A	P7	C195	G65
250*	CS1WN250A-PS	SDR-60	PNY-60	NLP-250A	P7	CS160-1618-G4	G80
300*	CS1WN300A-PS	SDR-70	PNY-70	NLP-300A	P7	CS160-1618-G5	G90

* Auto switch type is not available.

Lube style with auto switch

Bore (mm)	Kit No.	Wiper ring	Rod seal	Piston seal	Valve seal	Tube gasket	Holder plate gasket
125	CS1W125A-PS	SDR-36	P36	P115	P7	C120	G55
140	CS1W140A-PS	SDR-36	P36	P130	P7	C135	G55
160	CS1W160A-PS	SDR-40	P40	P150	P7	C155	G55
180	CDS1W180A-PS	SDR-45	P45	NLP-180A	P7	C175	G65
200	CDS1W200A-PS	SDR-50	P50A	NLP-200A	P7	C195	G65

Air-hydro style

Bore (mm)	Kit No.	Wiper ring	Rod seal	Piston seal	Valve seal	Tube gasket	Holder plate gasket
125	CS1WH125A-PS	SDR-36	SKY-36	RPS-125	P7	C120	G55
140	CS1WH140A-PS	SDR-36	SKY-36	RPS-140	P7	C135	G55
160	CS1WH160A-PS	SDR-40	SKY-40	RPS-160	P7	C155	G55

Air Cylinder/Double Rod Series CS1W

Construction

Lube/Non-lube/With auto switch

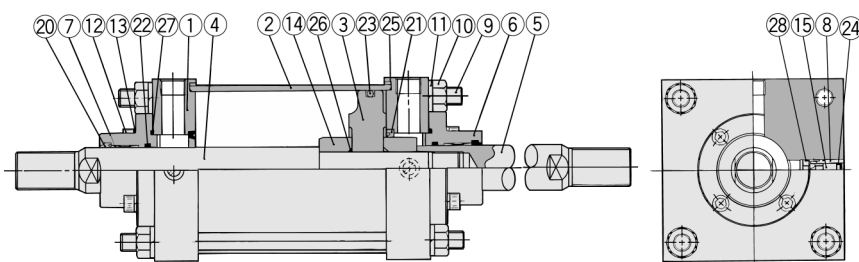
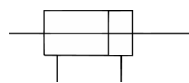

Non-lube

With auto switch

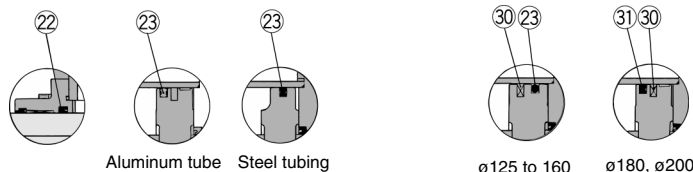

Air-hydro

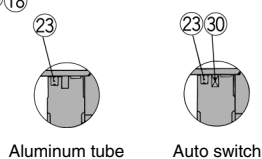
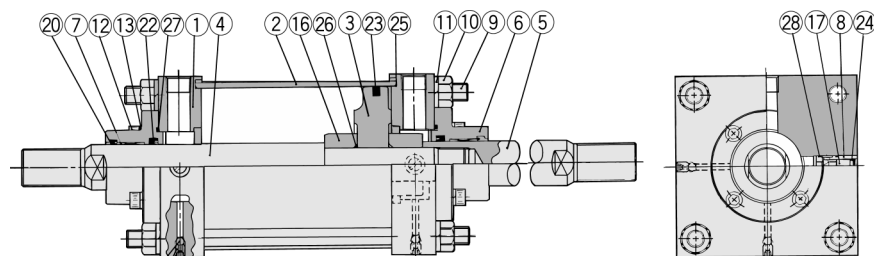
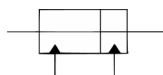

Component Parts

No.	Description	Material	Note
①	Rod cover	Rolled steel	Black coated
②	Cylinder tube	Ø 125 to Ø 160	Aluminum alloy Hard anodized
		Ø 125 to Ø 300**	Carbon steel tube Inside: Hard chrome plated
③	Piston	Cast iron**	
④	Piston rod A	Carbon steel	Hard chrome plated
⑤	Piston rod B	Carbon steel	Hard chrome plated
⑥	Holder plate	Cast iron	Black coated
⑦	Bushing	Lead bronze casting	
⑧	Valve guide	Brass	
⑨	Tie rod	Carbon steel	Chromed
⑩	Tie rod nut	Rolled steel	Black zinc chromated
⑪	Spring washer	Steel wire	Black zinc chromated
⑫	Holder plate bolt	Chrome-molybdenum steel	Black zinc chromated
⑬	Spring washer	Steel wire	Black zinc chromated
⑭	Cushion ring A	Rolled steel	Zinc chromated
⑮	Cushion valve	Rolled steel	Electroless nickel plated
⑯	Spacer A	Rolled steel	
⑰	Air releasing valve B	Rolled steel	Zinc chromated
⑱	Air releasing valve A	Chrome-molybdenum steel	
⑲	Check ball	Chrome bearing steel	
⑳	Magnet	—	

** In the case of the aluminum tube of non-lube and air-hydro type, piston material is an aluminum alloy casted. In the case of auto switch bore size Ø 180 and Ø 200, piston material is aluminum alloy casted and tubing material is aluminum alloy (hard anodized).

Seal List

No.	Description	Mat'l	Part No.						
			125	140	160	180	200	250	300
⑳	Wiper ring	NBR	SDR-36	SDR-36	SDR-40	SDR-45	SDR-50	SDR-60	SDR-70
㉑*	Cushion seal		DSM-50S	DSM-50S	DSM-50S	DSM-60S	DSM-60S	DSM-75S	PCS-85
㉒	Rod seal		P36	P36	P40	P45	P50A	P60	P70
㉓	Piston seal		P115	P130	P150	P165	P185	P235	P285
㉔	Valve seal		P7	P7	P7	P7	P7	P7	P7
㉕	Tube gasket		C120	C135	C155	C175	C195	CS160-1618-G4	CS160-1618-G5
㉖*	Piston gasket		G25	G25	G25	G35	G35	G45	G45
㉗	Holder plate gasket		G55	G55	G55	G65	G65	G80	G90
㉘*	Guide gasket		N-12.5-1.5	N-12.5-1.5	N-12.5-1.5	N-12.5-1.5	N-12.5-1.5	N-12.5-1.5	N-12.5-1.5

Non-lube Style Seals except ㉒ and ㉓ are the same as lube style.

No.	Description	Mat'l	125	140	160	180	200	250	300
㉒	Rod seal	NBR	PNY-36	PNY-36	PNY-40	PNY-45	PNY-50	PNY-60	PNY-70
㉓	Piston seal	NBR	NLP-125A	NLP-140A	NLP-160A	NLP-180A	NLP-200A	NLP-250A	NLP-300A

Air-hydro Style Seals except ㉒ and ㉓ are the same as lube style.

No.	Description	Mat'l	125	140	160
㉒	Rod seal	NBR	SKY-36	SKY-36	SKY-40
㉓	Piston seal	NBR	RPS-125	RPS-140	RPS-160

Lube Style (With switch) Seals except ㉓ are the same as lube style.

No.	Description	Mat'l	Part No.	
			180	200
㉓	Piston seal	NBR	NLP-180A	NLP-200A

Replacement Part (Seal kits)

- Refer to p.1.14-24 for replacement part no.(seal kits) of double rod style cylinder series CS1W.
- Seal set does not include cushion seal, piston seal and guide gasket because they are not replacement parts.

CJ1

CJP

CJ2

CM2

C85

C76

CG1

MB

MB1

CP95

C95

C92

CA1

CS1

Series CS1W

Basic/CS1WB

Lube (CS1WB), Non-lube (CS1WBN), Air-hydro (CS1WBH)

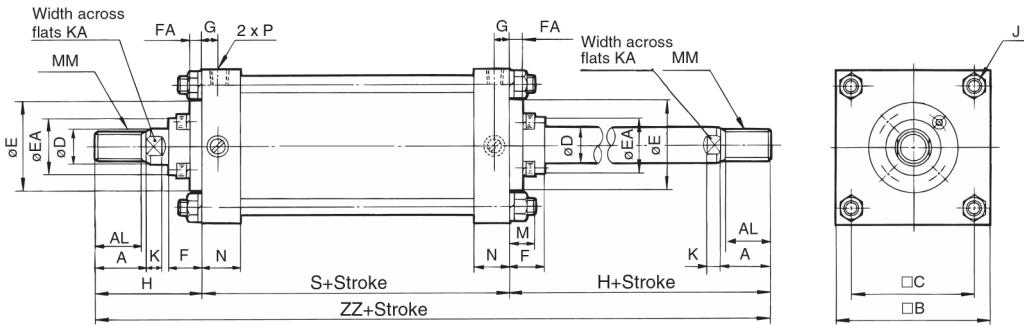

With single rod boot

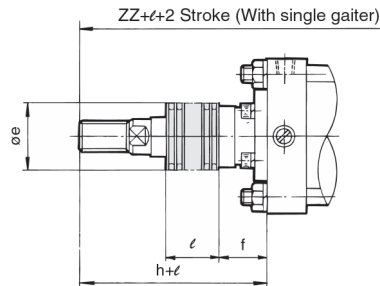

With double rod boot

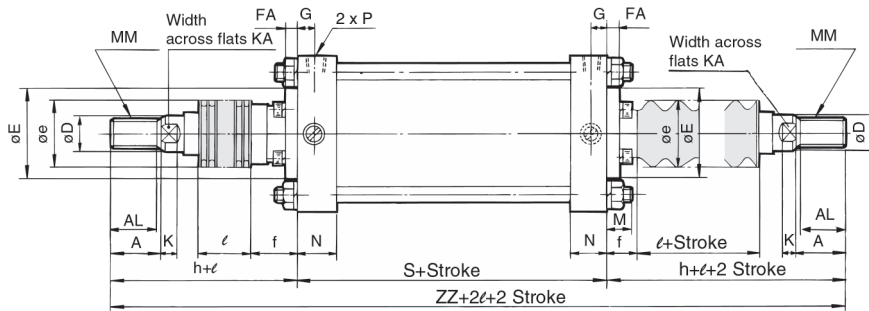

Style	Bore (mm)	Stroke range (mm)		A	AL	□B	□C	D	E	EA	F	FA	G	J	K	KA	M	MM	N	P	S
		W/o rod boot	W/ rod boot																		
Lube Non-lube Air-hydro	125	to 1000	30 to 1000	50	47	145	115	36	90	59	43	14	16	M14 X 1.5	15	31	27	M30 X 1.5	35	1/2	98
	140	to 1000	30 to 1000	50	47	161	128	36	90	59	43	14	16	M14 X 1.5	15	31	27	M30 X 1.5	35	1/2	98
	160	to 1200	30 to 1200	56	53	182	144	40	90	59	43	14	18.5	M16 X 1.5	17	36	30.5	M36 X 1.5	39	3/4	106
Lube Non-lube	180	to 1200	30 to 1200	63	60	204	162	45	115	70	48	17	18.5	M18 X 1.5	20	41	35	M40 X 1.5	39	3/4	111
	200	to 1200	30 to 1200	63	60	226	182	50	115	74	48	17	18.5	M20 X 1.5	20	46	35	M45 X 1.5	39	3/4	111
	250	to 1200	30 to 1200	71	67	277	225	60	140	86	60	20	23	M24 X 1.5	25	56	41.5	M56 X 2	49	1	141
	300	to 1200	30 to 1200	80	76	330	270	70	140	96	60	20	23	M30 X 1.5	30	65	51.5	M64 X 2	49	1	146

Style	Bore (mm)	W/o rod boot		W/ rod boot (Single side)					(Both sides)	
		H	ZZ	e	f	h	l	ZZ	ZZ	
Lube Non-lube Air-hydro	125	110	318	75	40	133	0.2 Stroke	341	364	
	140	110	318	75	40	133	0.2 Stroke	341	364	
	160	120	346	75	40	141	0.2 Stroke	367	388	
Lube Non-lube	180	135	381	85	45	153	0.2 Stroke	399	417	
	200	135	381	90	45	153	0.2 Stroke	399	417	
	250	160	461	105	55	176	0.17 Stroke	477	493	
	300	175	496	115	55	190	0.17 Stroke	511	526	

Style	Bore (mm)	Stroke range (mm)		S	W/ Rod boot		
		W/o rod boot	W/ rod boot		W/o rod boot	W/ Rod boot (Single side)	W/ Rod boot (Both sides)
Lube Non-lube Air-hydro	125	to 1000	30 to 1000	98	318	341	364
	140	to 1000	30 to 1000	98	318	341	364
	160	to 1200	30 to 1200	106	346	367	388
Lube Non-lube	180	to 1200	30 to 1200	115	385	403	421
	200	to 998	30 to 998	120	390	408	426

*** Refer to p.1.14-10 for auto switch min. mountable stroke.

Air Cylinder/Double Rod **Series CS1W**

Foot/CS1WL

Lube (CS1WL), Non-lube (CS1WLN), Air-hydro (CS1WLH)

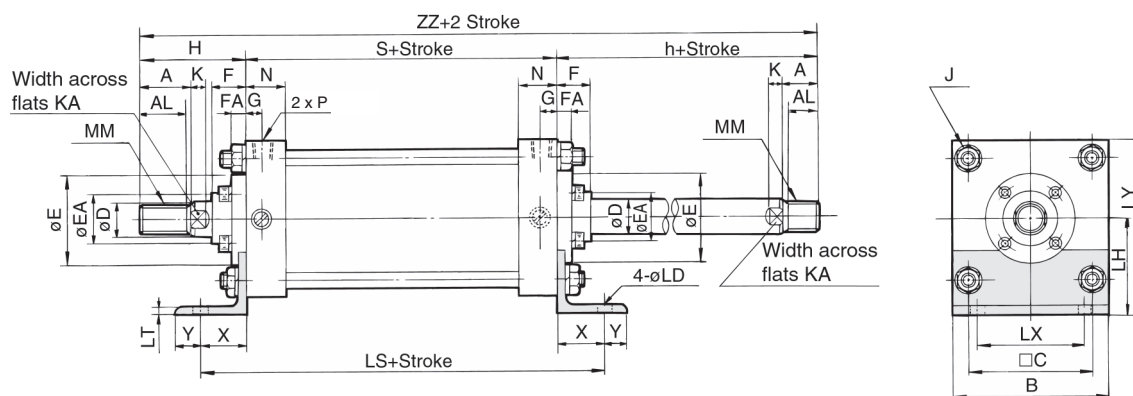

With rod boot

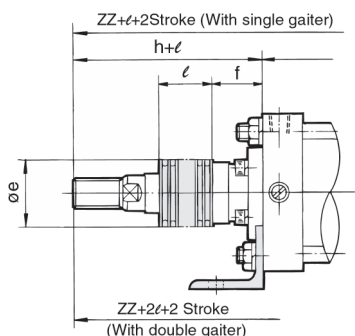

Style	Bore (mm)	Stroke range (mm)		A	AL	B	□C	D	E	EA	F	FA	G	J	K	KA	LD	LH	LS	LT
		W/o rod boot	W/ rod boot																	
Lube Non-lube Air-hydro	125	to 1000	30 to 1000	50	47	145	115	36	90	59	43	14	16	M14 X 1.5	15	31	19	85	188	8
	140	to 1000	30 to 1000	50	47	161	128	36	90	59	43	14	16	M14 X 1.5	15	31	19	100	188	9
	160	to 1200	30 to 1200	56	53	182	144	40	90	59	43	14	18.5	M16 X 1.5	17	36	19	106	206	9
Lube Non-lube	180	to 1200	30 to 1200	63	60	204	162	45	115	70	48	17	18.5	M18 X 1.5	20	41	24	125	231	10
	200	to 1200	30 to 1200	63	60	226	182	50	115	74	48	17	18.5	M20 X 1.5	20	46	24	132	231	10
	250	to 1200	30 to 1200	71	67	277	225	60	140	86	60	20	23	M24 X 1.5	25	56	29	160	301	12
	300	to 1200	30 to 1200	80	76	330	270	70	140	96	60	20	23	M30 X 1.5	30	65	33	200	326	15

Style	Bore (mm)	LX	LY	MM	N	P	S	X	Y	(mm)								
										W/o rod boot		W/ rod boot (Single side)					(Both sides)	
										H	ZZ	e	f	h	l	ZZ	ZZ	
Lube Non-lube Air-hydro	125	100	157.5	M30 X 1.5	35	1/2	98	45	20	110	318	75	40	133	0.2 Stroke	341	364	
	140	112	180.5	M30 X 1.5	35	1/2	98	45	30	110	318	75	40	133	0.2 Stroke	341	364	
	160	118	197	M36 X 1.5	39	3/4	106	50	25	120	346	75	40	141	0.2 Stroke	367	388	
Lube Non-lube	180	132	227	M40 X 1.5	39	3/4	111	60	30	135	381	85	45	153	0.2 Stroke	399	417	
	200	150	245	M45 X 1.5	39	3/4	111	60	30	135	381	90	45	153	0.2 Stroke	399	417	
	250	180	298.5	M56 X 2	49	1	141	80	40	160	461	105	55	176	0.17 Stroke	477	493	
	300	212	365	M64 X 2	49	1	146	90	40	175	496	115	55	190	0.17 Stroke	511	526	

With auto switch/Ø 125 to Ø 200 only

Style	Bore (mm)	Stroke range (mm)		S	LS	(mm)		
		W/o rod boot	W/ rod boot			W/ rod boot	W/ rod boot	W/ rod boot
		ZZ	ZZ			(Single side)	(Both sides)	
Lube Non-lube Air-hydro	125	to 1000	30 to 1000	98	188	318	341	364
	140	to 1000	30 to 1000	98	188	318	341	364
	160	to 1200	30 to 1200	106	206	346	367	388
Lube Non-lube	180	to 1200	30 to 1200	115	235	385	403	421
	200	to 998	30 to 998	120	240	390	408	426

*** Refer to p.1.14-10 for auto switch min. mountable stroke.

CJ1

CJP

CJ2

CM2

C85

C76

CG1

MB

MB1

CP95

C95

C92

CA1

CS1

Air Cylinder/Double Rod *Series CS1W*

Front Flange/CS1WF

Lube (CS1WF), Non-lube (CS1WFN), Air-hydro (CS1WFH)

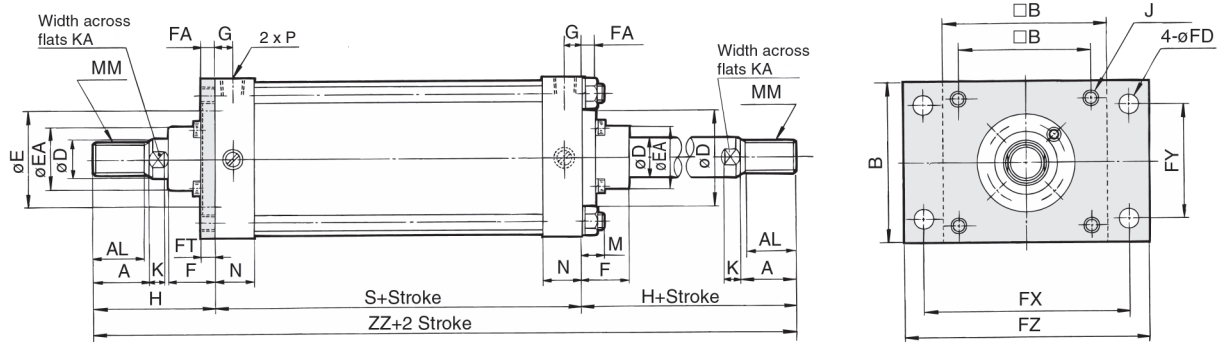

With rod boot

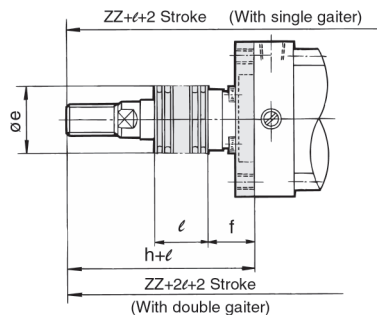

Style	Bore (mm)	Stroke range (mm)		A	AL	B	C	D	E	EA	F	FA	FD	FT	FX	FY	FZ	G	J	
		W/o rod boot	W/ rod boot																	
Lube Non-lube Air-hydro	125	to 1000	30 to 1000	50	47	145	145	115	36	90	59	43	14	19	14	190	100	230	16	M14 X 1.5
	140	to 1000	30 to 1000	50	47	160	161	128	36	90	59	43	14	19	20	212	112	255	16	M14 X 1.5
	160	to 1200	30 to 1200	56	53	180	182	144	40	90	59	43	14	19	20	236	118	275	18.5	M16 X 1.5
Lube Non-lube	180	to 1200	30 to 1200	63	60	200	204	162	45	115	70	48	17	24	25	265	132	320	18.5	M18 X 1.5
	200	to 1200	30 to 1200	63	60	225	226	182	50	115	74	48	17	24	25	280	150	335	18.5	M20 X 1.5
	250	to 1200	30 to 1200	71	67	275	277	225	60	140	86	60	20	29	30	355	180	420	23	M24 X 1.5
	300	to 1200	30 to 1200	80	76	330	330	270	70	140	96	60	20	33	30	400	212	475	23	M30 X 1.5

Style	Bore (mm)	K	KA	M	MM	N	P	S	W/o rod boot		W/ rod boot (Single side)				Both sides	
									H	ZZ	e	f	h	l	ZZ	ZZ
Lube Non-lube Air-hydro	125	15	31	30	M30 X 1.5	35	1/2	98	110	318	75	40	133	0.2 Stroke	341	364
	140	15	31	24	M30 X 1.5	35	1/2	98	110	318	75	40	133	0.2 Stroke	341	364
	160	17	36	26	M36 X 1.5	39	3/4	106	120	346	75	40	141	0.2 Stroke	367	388
Lube Non-lube	180	20	41	31	M40 X 1.5	39	3/4	111	135	381	85	45	153	0.2 Stroke	399	417
	200	20	46	31	M45 X 1.5	39	3/4	111	135	381	90	45	153	0.2 Stroke	399	417
	250	25	56	35	M56 X 2	49	1	141	160	461	105	55	176	0.17 Stroke	477	493
	300	30	65	48	M64 X 2	49	1	146	175	496	115	55	190	0.17 Stroke	511	526

With auto switch/Ø 125 to Ø 200 only

Style	Bore (mm)	Stroke range (mm)		S	W/o rod boot	W/ rod boot (Single side)	W/ rod boot (Both sides)
		W/o rod boot	W/ rod boot				
Lube Non-lube Air-lube	125	to 1000	30 to 1000	98	318	341	364
	140	to 1000	30 to 1000	98	318	341	364
	160	to 1200	30 to 1200	106	346	367	388
Lube Non-lube	180	to 1200	30 to 1200	115	385	403	421
	200	to 998	30 to 998	120	390	408	426

*** Refer to p.1.14-10 for auto switch min. mountable stroke.

Center Trunnion/CS1WT

Lube (CS1WT), Non-lube (CS1WTN), Air-hydro (CS1WTH)

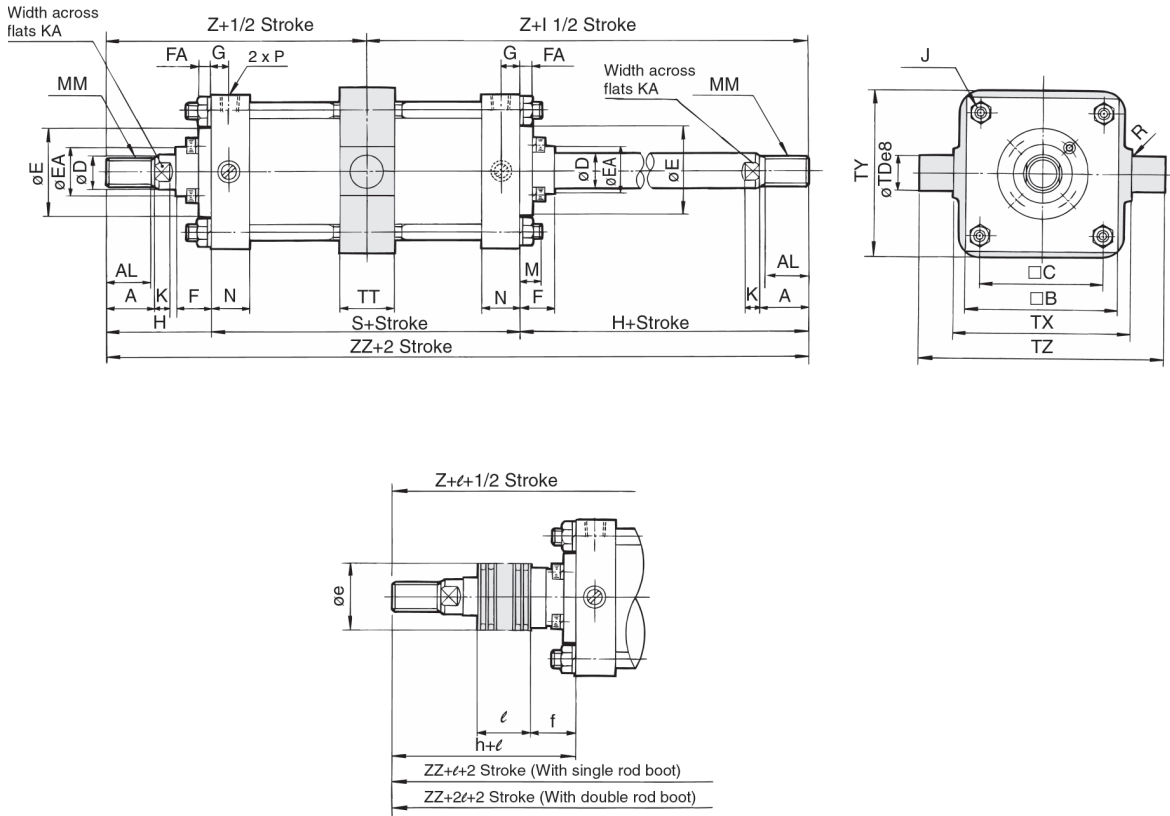

- CJ1**
- CJP**
- CJ2**
- CM2**
- C85**
- C76**
- CG1**
- MB**
- MB1**
- CP95**
- C95**
- C92**
- CA1**
- CS1**

Style	Bore (mm)	Stroke range (mm)		A	AL	□B	□C	D	E	EA	F	FA	G	J	K	KA	M	MM	N	P	R	S
		W/o rod boot	W/ rod boot																			
Lube	125	25 to 1000	30 to 1000	50	47	145	115	36	90	59	43	14	16	M14 X 1.5	15	31	19	M30 X 1.5	35	1/2	1	98
Non-lube	140	30 to 1000	30 to 1000	50	47	161	128	36	90	59	43	14	16	M14 X 1.5	15	31	19	M30 X 1.5	35	1/2	1.5	98
Air-hydro	160	35 to 1200	35 to 1200	56	53	182	144	40	90	59	43	14	18.5	M16 X 1.5	17	36	22	M36 X 1.5	39	3/4	1.5	106
Lube Non-lube	180	30 to 1200	30 to 1200	63	60	204	162	45	115	70	48	17	18.5	M18 X 1.5	20	41	26	M40 X 1.5	39	3/4	2	111
	200	30 to 1200	30 to 1200	63	60	226	182	50	115	74	48	17	18.5	M20 X 1.5	20	46	26	M45 X 1.5	39	3/4	2	111
	250	30 to 1200	30 to 1200	71	67	277	225	60	140	86	60	20	23	M24 X 1.5	25	56	30	M56 X 2	49	1	3	141
	300	35 to 1200	35 to 1200	80	76	330	270	70	140	96	60	20	23	M30 X 1.5	30	65	36	M64 X 2	49	1	4	146

Style	Bore (mm)	TDe ₈	TT	TX	TY	TZ	H	(mm)									
								W/o rod boot		W/ rod boot (Single side)						(Both sides)	
								Z	ZZ	e	f	h	l	Z	ZZ	Z	ZZ
Lube	125	32 ^{-0.050} _{-0.089}	50	170	164	234	110	159	318	75	40	133	0.2 Stroke	182	341	182	364
Non-lube	140	36 ^{-0.050} _{-0.089}	55	190	184	262	110	159	318	75	40	133	0.2 Stroke	182	341	182	364
Air-hydro	160	40 ^{-0.050} _{-0.089}	60	212	204	292	120	173	346	75	40	141	0.2 Stroke	194	367	194	388
Lube Non-lube	180	45 ^{-0.050} _{-0.089}	59	236	228	326	135	190.5	381	85	45	153	0.2 Stroke	208.5	399	208.5	417
	200	45 ^{-0.050} _{-0.089}	59	265	257	355	135	190.5	381	90	45	153	0.2 Stroke	208.5	399	208.5	417
	250	56 ^{-0.060} _{-0.106}	69	335	325	447	160	230.5	461	105	55	176	0.17 Stroke	246.5	477	246.5	493
	300	67 ^{-0.060} _{-0.106}	79	400	390	534	175	248	496	115	55	190	0.17 Stroke	263	511	263	526

Auto switch style/Ø 125 to Ø 200 only (mm)

Style	Bore (mm)	Stroke range (mm)		S	W/o rod boot		W/ rod boot (Single side)		W/ rod boot (Both sides)
		W/o rod boot	W/rod boot		Z	ZZ	Z	ZZ	ZZ
		Lube	125		25 to 1000	30 to 1000	98	159	318
Non-lube	140	30 to 1000	30 to 1000	98	159	318	182	341	364
Air-lube	160	35 to 1200	35 to 1200	106	173	346	194	367	388
Lube	180	30 to 1200	30 to 1200	115	192.5	385	210.5	403	421
Non-lube	200	30 to 998	30 to 998	120	195	390	213	408	426

*** Refer to p.1.14-10 for auto switch min. mountable stroke.

Air Cylinder/Low Friction

Series CS1□Q

Non-lube/Ø 125, Ø 140, Ø 160

How to Order

Standard CS1 L Q 160 300 JR

With auto switch CDS1 L Q 160 300 JR A53

Mounting

B	Basic
L	Foot
F	Front flange
G	Rear flange
C	Single clevis
D	Double clevis
T	Centre clevis

Low friction

Bore size

125	125 mm
140	140 mm
160	160 mm

Port thread type

—	Rc
TN	NPT
TF	G

Number of auto switches

—	2
S	1
3	3
n	n

Auto switch

—	Without auto switch
---	---------------------

Rod boot/Cushion

Rod boot	J	Nylon tarpaulin
	K	Heat resistant tarpaulin
Cushion	A	With double cushion
	R	With Front cushion
	H	With rear cushion
	—	Without cushion

Built-in magnet cylinder model

If a built-in magnet cylinder without auto switch is required, there is no need to enter the symbol for auto switch. (Example) CDS1WB125-200

Cylinder stroke (mm)

Refer to p.1.14-31 for the standard stroke.

Made to Order
(Refer to next page for details.)

* Select the applicable auto switch from the table below.

* If specifying more than one symbol, please indicate them in alphabetical order.

Applicable Auto Switches/Refer to auto switch guide for further information on auto switches.

Type	Special function	Electrical entry	Indicator light	Wiring (Output)	Load voltage		Auto switch model		Lead wire length (m)				Pre-wired connector	Applicable load		
					DC	AC	Tie-rod mounting	Band mounting	0.5 (—)	1 (M)	3 (L)	5 (Z)				
Solid state auto switch	—	Grommet	No	3-wire (NPN)	24 V	5 V, 12 V	—	M9N	●	●	●	○	○	IC circuit		
				3-wire (PNP)				M9P	●	●	●	○				
		2-wire		M9B	●	●	●	○	○	—						
		Terminal conduit		3-wire (NPN)	24 V	5 V, 12 V	—	G39	—	—	—	—	—	—	IC circuit	
	2-wire		K39	—				—	—	—	—	—				
	Diagnostic indication (2-color indicator)	Grommet	Yes	3-wire (NPN)	24 V	5 V, 12 V	—	M9NW	●	●	●	○	○	IC circuit		
				3-wire (PNP)				M9PW	●	●	●	○				
				2-wire	M9BW	●	●	●	○	○	—					
				Water resistant (2-color indicator)	3-wire (NPN)	24 V	5 V, 12 V	—	M9NA*1	—	○	○	●	○	○	IC circuit
	3-wire (PNP)	M9PA*1	—		○				○	●	○	○				
With diagnostic output (2-color indicator)	Grommet	Yes	2-wire	24 V	12 V	—	M9BA*1	—	○	○	●	○	○	—		
			4-wire (NPN)				F59F	—	●	—	●	○	○	IC circuit		
Magnetic field resistant (2-color indicator)	Grommet	Yes	2-wire (Non-polar)	24 V	—	—	P3DWA	—	●	—	●	●	○	—		
			3-wire (NPN equivalent)				A96	—	●	—	●	—	—	IC circuit		
Reed auto switch	—	Grommet	No	2-wire	24 V	12 V	100 V	A93	—	●	●	●	—	—		
								5 V, 12 V	A90	—	●	—	●	—	—	IC circuit
								100 V, 200 V	A54	—	●	—	●	—	—	
		Terminal conduit	No	2-wire	24 V	12 V	—	—	A64	—	●	—	●	—	—	
									—	A33	—	—	—	—	—	—
		DIN terminal	Yes	2-wire	24 V	100 V, 200 V	—	—	A34	—	—	—	—	—	—	
									—	A44	—	—	—	—	—	—
Diagnostic indication (2-color indicator)	Grommet	Yes	2-wire	24 V	—	—	A59W	—	●	—	●	—	—			

*1 Water resistant type auto switches can be mounted on the above models, but in such case SMC cannot guarantee water resistance. Consult with SMC regarding water resistant types with the above model numbers.

* Lead wire length symbols: 0.5 m — (Example) M9NW * Solid state auto switches marked with "○" are produced upon receipt of order.
 1 m M (Example) M9NWM
 3 m L (Example) M9NLW
 5 m Z (Example) M9NWZ

* Since there are other applicable auto switches than listed above, refer to page 1.14-36 for details.
 * For details about auto switches with pre-wired connector, refer to auto switch guide.
 * D-A9□/M9□/M9□W/M9□A/P3DWA□ auto switches are shipped together (not assembled). (Only auto switch mounting brackets are assembled before shipped.)

Designed with a low sliding resistance of the piston, this air cylinder is ideal for applications such as contact pressure control, which requires smooth movements at low pressures.

Low sliding resistance
Min. operating pressure – 0.005 MPa

Auto switch mounting is possible.

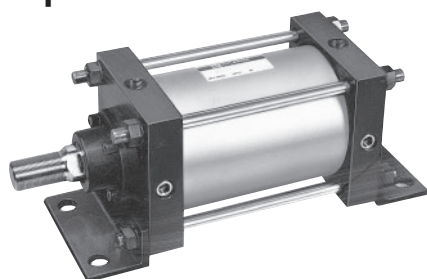

Symbol

Double acting, Without cushion

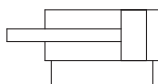

Made to Order Specifications

Symbol	Specifications
-XA□	Change of rod end shape
-XC3	Special port location
-XC14	Change of trunnion bracket mounting position
-XC15	Change of tie-rod length
-XC26	Clevis pins with flat washer
-XC27	Double clevis pins made of stainless steel (Stainless steel 304)
-XC30	Rod side trunnion



Precautions

Be sure to read before handling. Refer to p.0-39 to 0-43 for Safety Instructions and common precautions.

Cylinder with auto switch

Refer to the standard style double acting single rod (Series CS1) on p.1.14-9 for auto switch specifications of low friction style.

Application Example

A low friction cylinder is used in combination with a precision regulator (Series IR, etc.).

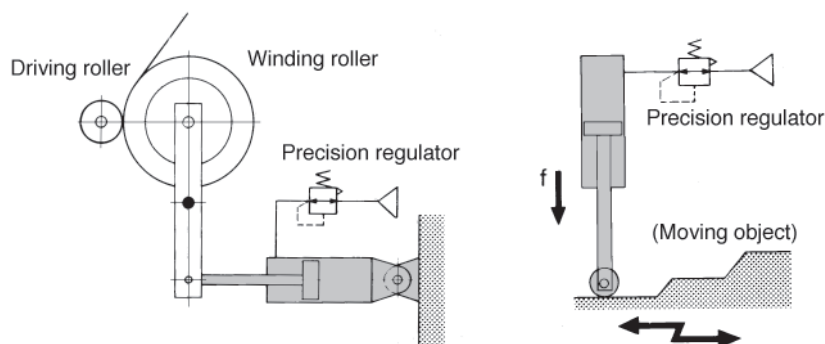

Specifications

Action	Double acting single rod
Direction of low friction	Both directions
Fluid	Air
Proof pressure	1.05 MPa
Max. operating pressure	0.7 MPa
Min. operating pressure	0.005 MPa*
Ambient and fluid temperature	Without auto switch: 0 to 70 °C (No condensation), With auto switch: 0 to 60 °C (No condensation)
Allowable leakage rate	0.5 l/min (ANR) or less
Cushion	None (Cushion style is available.)
Thread tolerance	JIS 2 class
Lube	Not required (Non-lube)
Bore size (mm)	Ø 125, Ø 140, Ø 160
Mounting	Basic, Foot, Front flange, Rear flange, Single clevis, Double clevis, Centre trunnion

* In case of cushion style, pressure inside cushion stroke is not included.

Max. Stroke

Tube material	Aluminum alloy		Carbon steel	
	Basic, Rear flange, Single clevis, Double clevis, Centre trunnion	Front flange	Basic, Rear flange, Single clevis, Double clevis, Centre trunnion	Foot, Front flange
Bore size (mm)				
125	1000 or less	1400 or less	1000 or less	1600 or less
140	1000 or less	1400 or less	1000 or less	1600 or less
160	1200 or less	1400 or less	1200 or less	1600 or less

Mounting Bracket Part No.

Bore size (mm)	125	140	160
Foot*	CS1-L12	CS1-L14	CS1-L16
Flange	CS1-F12	CS1-F14	CS1-F16
Single clevis	CS1-C12	CS1-C14	CS1-C16
Double clevis	CS1-D12	CS1-D14	CS1-D16

* Order 2 foot brackets for one cylinder.

CJ1

CJP

CJ2

CM2

C85

C76

CG1

MB

MB1

CP95

C95

C92

CA1

CS1

Series CS1□Q

Accessories

Mounting		Basic	Foot	Front flange	Rear flange	Single clevis	Double clevis	Center trunnion
Std. equipment	Clevis pin	—	—	—	—	—	●	—
Accessory	Rod end nut	●	●	●	●	●	●	●
	Single knuckle joint	●	●	●	●	●	●	●
	Double knuckle joint (Knuckle pin, Cotter pin)	●	●	●	●	●	●	●
	Rod boot	●	●	●	●	●	●	●

Rod Boot Materials

Symbol	Material	Max. ambient temp
J	Nylon tarpaulin	60 °C
K	Heat resistant tarpaulin	110 °C*

* Max. ambient temperature for the rod boot itself.

Major Material and Surface Treatments

Description	Material	Note
Cover	Rolled steel	Black painted
Tube	Aluminum alloy *	Hard anodized
	Carbon steel pipe	Inside: Hard chrome plated
Sliding part seal	NBR	
Piston rod	Carbon steel	Hard chrome plated
Piston	Aluminum alloy cast	Chromated

* With auto switch

Weight/Steel tube (Refer to p.1.14-6 for aluminum tube [With auto switch].) (kg)

Bore size (mm)		Ø 125	Ø 140	Ø 160
Basic weight	Basic	15.20	18.38	25.24
	Foot	16.83	20.90	28.04
	Front flange	17.88	23.38	31.63
	Rear flange	17.88	23.38	31.63
	Single clevis	18.27	22.67	30.73
	Double clevis	18.73	23.42	31.58
	Trunnion	19.33	24.11	32.64
Additional weight per 100 stroke		2.66	3.01	3.58
Accessory	Single knuckle joint	0.91	1.16	1.56
	Double knuckle joint (with pin)	1.37	1.81	2.48

Calculation example: **CS1LQ160, 500** (Foot, Ø 160)

- Basic weight 28.04
 - Additional weight 3.58/100 stroke
 - Cylinder stroke 500 stroke
- 28.04+3.58 X 500/100= 45.94 kg

Sliding Resistance

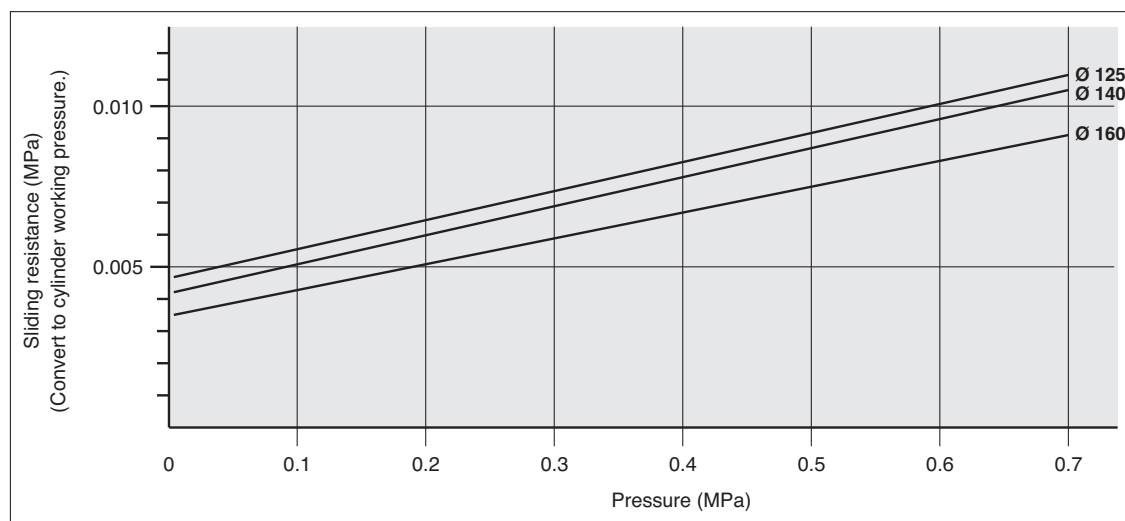

Air Cylinder/Low Friction Series CS1□Q

Construction

Non-lube

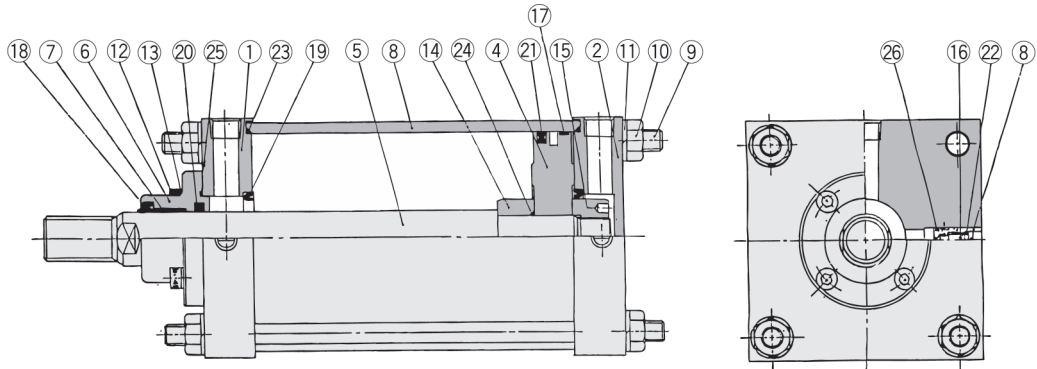
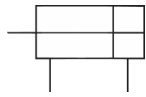

Component Parts

No.	Description	Material	Note
①	Rod cover	Rolled steel plate	Black coated
②	Head cover	Rolled steel plate	Black coated
③	Cylinder tube	Aluminum alloy*	Hard anodized
		Carbon steel pipe	Hard chrome plated
④	Piston	Aluminum alloy die cast	Chromated
⑤	Piston rod	Carbon steel	Hard chrome plated
⑥	Holder plate	Cast iron	Black coated
⑦	Bushing	Lead bronze casting	
⑧	Valve guide	Brass	
⑨	Tie rod	Carbon steel	Chromated
⑩	Tie rod nut	Rolled steel	Black zinc chromated
⑪	Spring washer	Steel wire	Black zinc chromated
⑫	Holder plate bolt	Chrome-molybdenum steel	Black zinc chromated
⑬	Spring washer	Steel wire	Black zinc chromated
⑭	Cushion ring A	Rolled steel	Zinc chromated
⑮	Cushion ring B	Rolled steel	Zinc chromated
⑯	Cushion valve	Rolled steel	Nickel plated
⑰	Wear ring	Resin	

* With auto switch

Seal List

No.	Description	Mat'l	Part No.		
			125	140	160
⑱	Wiper ring	NBR	SFR-36K	SFR-36K	SFR-40K
⑲	Cushion seal*		DSM-50S	DSM-50S	DSM-50S
⑳	Rod seal		PNY-36	PNY-36	PNY-40
㉑	Piston seal		NLP-125A	NLP-140A	NLP-160A
㉒	Valve seal		P7	P7	P7
㉓	Tube gasket		C120	C135	C155
㉔	Piston gasket		G25		
㉕	Holder plate gasket		G55		
㉖	Guide gasket		N-12.5-1.5		

*It is used in case of cushion style only.

According to Mounting Brackets/Dimensions

Refer to dimensions of the standard style on p.1.14-14 to 1.14-20 for those with mounting brackets except the basic style.

Basic/CS1BQ

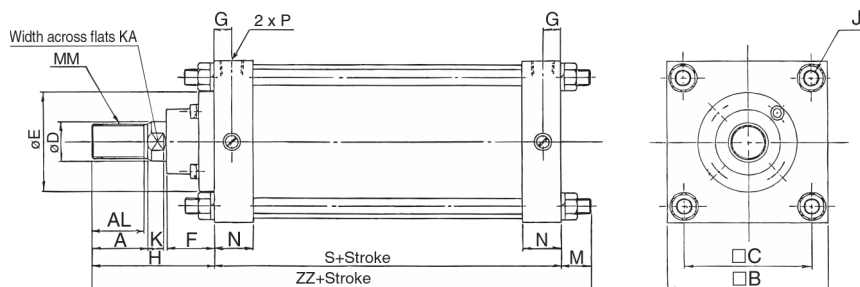

Bore (mm)	Stroke range (mm)	A	AL	□B	□C	D	E	F	G	J	K	KA	M	MM	N	P	S	H	ZZ
125	to 1000	50	47	145	115	36	90	43	16	M14 X 1.5	15	31	27	M30 X 1.5	35	1/2	98	110	235
140	to 1000	50	47	161	128	36	90	43	16	M14 X 1.5	15	31	27	M30 X 1.5	35	1/2	98	110	235
160	to 1200	56	53	182	144	40	90	43	18.5	M16 X 1.5	17	36	30.5	M36 X 1.5	39	3/4	106	120	256.5

(mm)

CS1 Series

Auto Switch Mounting 1

Proper Auto Switch Mounting Position (Detection at stroke end) and Mounting Height

Band mounting type

D-A3□
D-G3/K3

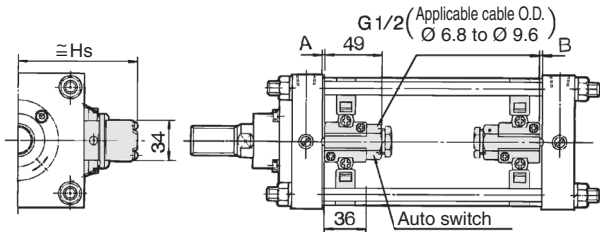

D-A44

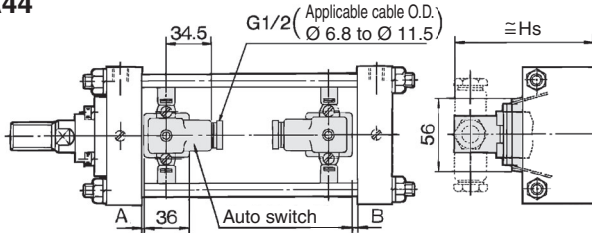

Tie-rod mounting type

D-M9□/M9□V D-Z7□/Z80
D-M9□W/M9□WV D-Y59□/Y69□/Y7P/Y7PV
D-M9□A/M9□AV D-Y7□W/Y7□WV
D-A9□/A9□V D-Y7BA

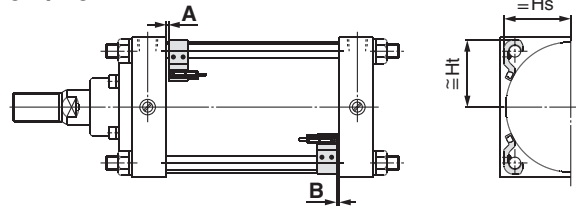

D-A5□/A6□

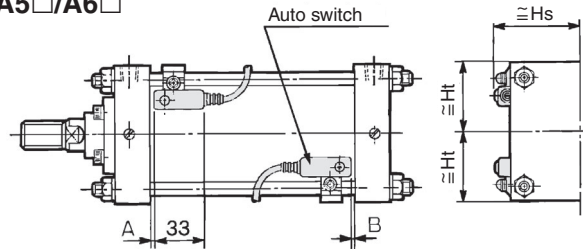

D-F5□/J59/D-F5NT

D-F5BA/F59F
D-F5□W/J59W

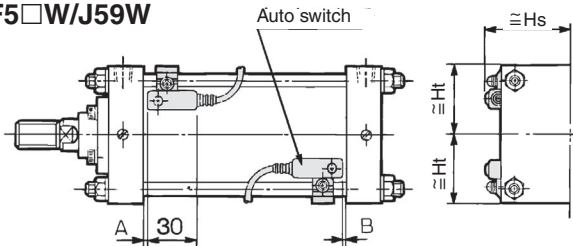

D-P3DWA

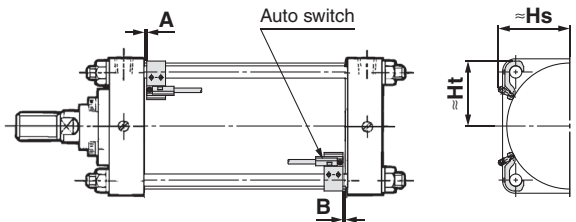

Proper Auto Switch Mounting Position

(mm)

Auto switch model	D-M9□ D-M9□V D-M9□W D-M9□WV D-M9□A D-M9□AV		D-A9□ D-A9□V		D-Z7□/Z80 D-Y5□/Y6□ D-Y7P/Y7PV D-Y7□W D-Y7□WV D-Y7BA		D-A5□ D-A6□ D-A3□ D-A44 D-G39 D-K39		D-A59W		D-F5□W D-J59W D-F5BA D-F5□ D-J59 D-F59F		D-F5NT		D-P3DWA	
	A	B	A	B	A	B	A	B	A	B	A	B	A	B	A	B
Bore size																
125	8	8	4	4	1.5	1.5	0	0	2	2	4.5	4.5	9.5	9.5	3.5	3.5
140	8	8	4	4	1.5	1.5	0	0	2	2	4.5	4.5	9.5	9.5	3.5	3.5
160	8	8	4	4	1.5	1.5	0	0	2	2	4.5	4.5	9.5	9.5	3.5	3.5
180	13.5	12.5	9.5	7.5	7	5	3.5	1.5	7.5	5.5	10	8	15	13	9	7
200	16	14	12	10	9.5	7.5	6	4	10	8	12.5	10.5	17.5	15.5	11.5	9.5

* The mounting position should be referred for reference only for the auto switch mounting position at the stroke end detection.

Adjust the auto switch after confirming the operation to set actually.

* Low friction type (CDS1□Q): Ø 125, Ø 140, Ø 160

Auto Switch Mounting Height

(mm)

Auto switch model	D-M9□ D-M9□W D-M9□A D-A9□ D-A9□V		D-M9□WV D-M9□AV D-M9□V		D-Z7□/Z80 D-Y5□/Y6□ D-Y7P D-Y7PV D-Y7□W D-Y7□WV D-Y7BA		D-A3□ D-G39 D-K39	D-A44	D-A5□ D-A6□ D-A59W		D-F5□ D-J59 D-F5□W D-J59W D-F5BA D-F59F D-F5NT		D-P3DWA	
	Hs	Ht	Hs	Ht	Hs	Ht	Hs	Ht	Hs	Ht	Hs	Ht	Hs	Ht
Bore size														
125	69	69.5	71.5	69.5	69	69.5	116	126	75.5	69.5	74.5	70	76	69.5
140	76	76	77.5	76	76	76	124	134	81	76.5	80	76.5	82	76
160	85	85	86	85	85	85	134.5	144.5	89	87.5	88	87.5	91	85
180	95	95	95.5	95	95	95	144	154	97	97.5	96	97.5	100	95
200	106	106	106	106	106	106	154	164	107	108	107.5	108	111	106

* Low friction type (CDS1□Q): Ø 125, Ø 140, Ø 160

Auto Switch Mounting 2

Minimum Stroke for Auto Switch Mounting

n: No. of auto switch (mm)

Auto switch model No.	No. of auto switch mounted	Bracket other than center trunnion	Center trunnion type					
			Ø 125	Ø 140	Ø 160	Ø 180	Ø 200	
D-M9□ D-M9□W	2 (Different surfaces, Same surface) 1	15	105	110	115			
	n	$15 + 40 \frac{(n-2)}{2}$ (n = 2, 4, 6, 8...) ^{Note 1}	$105 + 40 \frac{(n-4)}{2}$ (n = 4, 8, 12, 16...) ^{Note 2}	$110 + 40 \frac{(n-4)}{2}$ (n = 4, 8, 12, 16...) ^{Note 2}	$115 + 40 \frac{(n-4)}{2}$ (n = 4, 8, 12, 16...) ^{Note 2}			
D-M9□V D-M9□WV	2 (Different surfaces, Same surface) 1	10	80	85	90			
	n	$10 + 30 \frac{(n-2)}{2}$ (n = 2, 4, 6, 8...) ^{Note 1}	$80 + 30 \frac{(n-4)}{2}$ (n = 4, 8, 12, 16...) ^{Note 2}	$85 + 30 \frac{(n-4)}{2}$ (n = 4, 8, 12, 16...) ^{Note 2}	$90 + 30 \frac{(n-4)}{2}$ (n = 4, 8, 12, 16...) ^{Note 2}			
D-M9□A	2 (Different surfaces, Same surface) 1	20	115	120				
	n	$20 + 40 \frac{(n-2)}{2}$ (n = 2, 4, 6, 8...) ^{Note 1}	$115 + 40 \frac{(n-2)}{2}$ (n = 4, 8, 12, 16...) ^{Note 2}	$120 + 40 \frac{(n-2)}{2}$ (n = 4, 8, 12, 16...) ^{Note 2}				
D-M9□AV	2 (Different surfaces, Same surface) 1	15	90	95				
	n	$15 + 30 \frac{(n-2)}{2}$ (n = 2, 4, 6, 8...) ^{Note 1}	$90 + 30 \frac{(n-2)}{2}$ (n = 4, 8, 12, 16...) ^{Note 2}	$95 + 30 \frac{(n-2)}{2}$ (n = 4, 8, 12, 16...) ^{Note 2}				
D-A9□	2 (Different surfaces, Same surface) 1	15	100	105	110			
	n	$15 + 40 \frac{(n-2)}{2}$ (n = 2, 4, 6, 8...) ^{Note 1}	$100 + 40 \frac{(n-4)}{2}$ (n = 4, 8, 12, 16...) ^{Note 2}	$105 + 40 \frac{(n-4)}{2}$ (n = 4, 8, 12, 16...) ^{Note 2}	$110 + 40 \frac{(n-4)}{2}$ (n = 4, 8, 12, 16...) ^{Note 2}			
D-A9□V	2 (Different surfaces, Same surface) 1	10	75	80	85			
	n	$10 + 30 \frac{(n-2)}{2}$ (n = 2, 4, 6, 8...) ^{Note 1}	$75 + 30 \frac{(n-4)}{2}$ (n = 4, 8, 12, 16...) ^{Note 2}	$80 + 30 \frac{(n-4)}{2}$ (n = 4, 8, 12, 16...) ^{Note 2}	$85 + 30 \frac{(n-4)}{2}$ (n = 4, 8, 12, 16...) ^{Note 2}			
D-A5□/A6□ D-A59W D-F5□/J59 D-F5□W D-J59W D-F5BA D-F59F	2 (Different surfaces, Same surface) 1	25	125	135		150		
	n (Same surface)	$25 + 55 \frac{(n-2)}{2}$ (n = 2, 4, 6, 8...) ^{Note 1}	$125 + 55 \frac{(n-4)}{2}$ (n = 4, 8, 12, 16...) ^{Note 2}	$135 + 55 \frac{(n-4)}{2}$ (n = 4, 8, 12, 16...) ^{Note 2}		$150 + 55 \frac{(n-4)}{2}$ (n = 4, 8, 12, 16...) ^{Note 2}		
D-F5NT	2 (Different surfaces, Same surface) 1	35	145	155		170		
	n (Same surface)	$35 + 55 \frac{(n-2)}{2}$ (n = 2, 4, 6, 8...) ^{Note 1}	$145 + 55 \frac{(n-4)}{2}$ (n = 4, 8, 12, 16...) ^{Note 2}	$155 + 55 \frac{(n-4)}{2}$ (n = 4, 8, 12, 16...) ^{Note 2}		$170 + 55 \frac{(n-4)}{2}$ (n = 4, 8, 12, 16...) ^{Note 2}		
D-A3□ D-G39 D-K39	2	Different surfaces	35	110				150
		Same surface	100					
	n	Different surfaces	$35 + 30(n-2)$ (n = 2, 3, 4, 5...)	$110 + 30(n-2)$ (n = 2, 4, 6, 8...) ^{Note 1}				$150 + 100(n-2)$ (n = 2, 4, 6, 8...) ^{Note 1}
		Same surface	$100 + 100(n-2)$ (n = 2, 3, 4, 5...)	$110 + 100(n-2)$ (n = 2, 4, 6, 8...) ^{Note 1}				$150 + 30(n-2)$ (n = 2, 4, 6, 8...) ^{Note 1}
1	15	110				150		
D-A44	2	Different surfaces	35	110				150
		Same surface	55					
	n	Different surfaces	$35 + 30(n-2)$ (n = 2, 3, 4, 5...)	$110 + 30(n-2)$ (n = 2, 4, 6, 8...) ^{Note 1}				$150 + 30(n-2)$ (n = 2, 4, 6, 8...) ^{Note 1}
		Same surface	$55 + 55(n-2)$ (n = 2, 3, 4, 5...)	$110 + 50(n-2)$ (n = 2, 4, 6, 8...) ^{Note 1}				$150 + 50(n-2)$ (n = 2, 4, 6, 8...) ^{Note 1}
1	15	110				150		
D-Z7□ D-Z80 D-Y59□ D-Y7P D-Y7□W	2 (Different surfaces, Same surface) 1	15	105	110	115			
	n	$15 + 40 \frac{(n-2)}{2}$ (n = 2, 4, 6, 8...) ^{Note 1}	$105 + 40 \frac{(n-4)}{2}$ (n = 4, 8, 12, 16...) ^{Note 2}	$110 + 40 \frac{(n-4)}{2}$ (n = 4, 8, 12, 16...) ^{Note 2}	$115 + 40 \frac{(n-4)}{2}$ (n = 4, 8, 12, 16...) ^{Note 2}			
D-Y69□ D-Y7PV D-Y7□WV	2 (Different surfaces, Same surface) 1	10	90	95	100			
	n	$10 + 30 \frac{(n-2)}{2}$ (n = 2, 4, 6, 8...) ^{Note 1}	$90 + 30 \frac{(n-4)}{2}$ (n = 4, 8, 12, 16...) ^{Note 2}	$95 + 30 \frac{(n-4)}{2}$ (n = 4, 8, 12, 16...) ^{Note 2}	$100 + 30 \frac{(n-4)}{2}$ (n = 4, 8, 12, 16...) ^{Note 2}			
D-Y7BA	2 (Different surfaces, Same surface) 1	20	115	120	125	130		
	n	$20 + 45 \frac{(n-2)}{2}$ (n = 2, 4, 6, 8...) ^{Note 1}	$115 + 45 \frac{(n-4)}{2}$ (n = 4, 8, 12, 16...) ^{Note 2}	$120 + 45 \frac{(n-4)}{2}$ (n = 4, 8, 12, 16...) ^{Note 2}	$125 + 45 \frac{(n-4)}{2}$ (n = 4, 8, 12, 16...) ^{Note 2}	$130 + 45 \frac{(n-4)}{2}$ (n = 4, 8, 12, 16...) ^{Note 2}		
D-P3DWA	2 (Different surfaces, Same surface) 1	20	110	115	120			
	n	$20 + 50 \frac{(n-2)}{2}$ (n = 2, 4, 6, 8...) ^{Note 1}	$110 + 50 \frac{(n-4)}{2}$ (n = 4, 8, 12, 16...) ^{Note 2}	$115 + 50 \frac{(n-4)}{2}$ (n = 4, 8, 12, 16...) ^{Note 2}	$120 + 50 \frac{(n-4)}{2}$ (n = 4, 8, 12, 16...) ^{Note 2}			

* Low friction type (CDS1□Q): Ø 125, Ø 140, Ø 160

Note 1) When "n" is an odd number, an even number that is one larger than this odd number is used for the calculation.
Note 2) When "n" is an odd number, a multiple of 4 that is larger than this odd number is used for the calculation.

CJ1
CJP
CJ2
CM2
C85
C76
CG1
MB
MB1
CP95
C95
C92
CA1
CS1

CS1 Series

Operating range

Auto switch type	Bore size (mm)				
	125	140	160	180	200
D-M9□/M9□V D-M9□W/M9□WV D-M9□A/M9□AV	6	6.5	6.5	6.5	7
D-A9□/A9□V	12	12.5	11.5	12	12.5
D-Z7□/Z80	14	14.5	13	14	14.5
D-A3□/A44 D-A5□/A6□	10	10	10	10	10
D-A59W	17	17	17	17	17
D-Y59□/Y69□ D-Y7P/Y7PV D-Y7□W/Y7□WV D-Y7BA	12	13	7	7.5	8
D-F5□/J59/F5□W D-J59W/F5BA D-F5NT/F59F	5	5	5.5	6	6
D-G39/K39	11	11	10	10	10
D-P3DWA	6	6.5	6.5	6.5	7

- * Since this is a guideline including hysteresis, not meant to be guaranteed. (Assuming approximately ±30 % dispersion.)
There may be the case it will vary substantially depending on an ambient environment.
- * Low friction type (CDS1□Q): Ø 125, Ø 140, Ø 160

Auto Switch Mounting Bracket: Part No.

Auto switch type	Bore size (mm)				
	Ø 125	Ø 140	Ø 160	Ø 180	Ø 200
D-M9□/M9□V D-M9□W/M9□WV D-M9□A/M9□AV D-A9□/A9□V	BS5-125	BS5-125	BS5-160	BS5-180	BS5-200
D-A5□/A6□ D-A59W D-F5□/J59 D-F5NT D-F5□W/J59W D-F5BA/F59F	BT-12	BT-12	BT-16	BT-18A	BT-20
D-A3□/A44 D-G39/K39	BS1-125	BS1-140	BS1-160	BS1-180	BS1-200
D-Z7□/Z80 D-Y59□/Y69□ D-Y7P/Y7PV D-Y7□W/Y7□WV D-Y7BA	BS4-125	BS4-125	BS4-160	BS4-180	BS4-200
D-P3DWA	BS7-125S	BS7-125S	BS7-160S	BS7-180S	BS7-200S

[Stainless Steel Mounting Screw Kit]

The following set of stainless steel mounting screws is available. Use them in accordance with the operating environment. (Since auto switch brackets are not included, order them separately.)

BBA1: For D-A5/A6/F5/J5 types

The above stainless steel screws are used when a cylinder is shipped with D-F5BA-type auto switches.

When only a switch is shipped independently, BBA1 screws are attached.

Note) When D-M9□A/M9□AV/Y7BA auto switches are used, do not use steel set screws included in the auto switch mounting brackets above (BS5-□□□ and BS4-□□□). Order the stainless steel screw set BBA1 separately, and use M4 x 8L stainless steel set screws included in BBA1 instead.

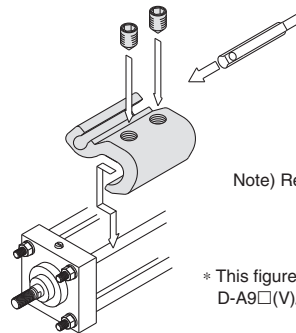

Note) Refer to BBA1 screws.

* This figure shows how to mount D-A9□(V)/M9□(V)/M9□W(V)/M9□A(V).

Besides the models listed in How to Order, the following auto switches are applicable.

Auto switch type	Mounting method	Options
Reed	Grommet (perpendicular)	Without indicator light
		—
		Without indicator light
	Grommet (in-line)	—
		Water resistant (2 colors)
		Water resistant (2 colors)
Solid state	Grommet (in-line)	Con temporizador
		—
		2-color display
	Grommet (perpendicular)	Water resistant (2 colors)
		—
		2-color display
		Water resistant (2 colors)
		—
		2-color display
		Water resistant (2 colors)

* For solid state auto switches, auto switches with a pre-wired connector are also available. Refer to auto switch guide for details.

* Normally closed (NC = b contact) solid state auto switches (D-F9G/F9H/Y7G/Y7Htypes) are also available. Refer to auto switch guide for details.